

# PVVF

## Positioner

### Parameter Setting Manual

### Smart Valve Positioners

### ASD-5 & ASD-7 Series

(Standard/Segmented Display)



## PVF Positioner



**Table of contents**

1. General details.....	4
1.1. Quick Auto Calibration.....	4
1.2. Display Description.....	4
2. Main parameter.....	5
2.1. Main parameter flowchart.....	5
2.2. Main Menu Description.....	6
2.3. Parameter.....	7
2.3.1. Main Parameter.....	7
2.3.2. CONTROL Parameter.....	7
2.3.3. SUB Parameter.....	7
3. Main parameters settings.....	8
3.1. [LOCK] LOCK ON / OFF.....	8
3.2. [DISP] Change display value.....	9
3.3. [MAN] Manual Mode.....	10
3.4. [MON] Monitoring Mode.....	11
3.5. [AUTO] Auto-Calibration Mode.....	12
3.5.1. [TUNE] Auto Calibration.....	13
3.5.2. [RESER] Parameter initialization.....	14
3.5.3. [STA/END] Readjust START & END Positions.....	14
3.5.4.[COLD] Restart.....	14
3.6.[TEST] Test Mode.....	15
3.6.1. [ST TEST] Valve test.....	15
3.6.2. [INSTALL] Check installation status.....	16
4. Parameter.....	17
4.1. Parameter Flow Chart.....	17
4.2. [INPUT] Change input signal (Default Value: 4-20mA).....	18
4.3. [RA/DA] Select Direct acting (DA) / Reverse acting (RA) (Default Value: Automatic setting).....	18
4.4. [LIN/EQ%] Change Linear, EQ%, Quick, User set operation characteristics (Default Value: Linear)....	19
4.4.1. [LIN/EQ/QUICK].....	19
4.4.2. [USER] User characteristic.....	20
4.5. [SPAN] Change span value (Default Value: 100).....	21
4.6. [ZERO] Change zero (Default Value: 0).....	21
4.7. PID-Gain.....	22
4.7.1. [P-GAIN] Proportional Gain.....	22
4.7.2. [I-GAIN] Integral Gain.....	23
4.7.3. [D-GAIN] Differential Gain.....	23
4.8.[CTRL] – Control Setting Parameter.....	24
This is a parameter related to control. CONTROL Parameters include speed settings, control limit settings, sensitivity settings, linearization, and friction mode settings.....	24
4.8.1. [SPEED] – Adjust operation speed (Default Value: 995).....	24

- 4.8.2.[DAMP 1] – Maximum control amount (Default Value: automatic setting).....25
- 4.8.3. [DAMP 2] – Maximum section control amount (default: automatic setting).....26
- 4.8.4. [SENS] – Sensitivity Settings (Default Value: MIDDLE).....27
- 4.8.5. [LINEARI] Linearization compensation control.....28
- 4.8.6.[FRICTIO] FRICTION Compensation control (Default Value : NORMAL).....29
- 4.9.[DEADZON] Dead zone setting (Default Value: 0.3).....29
- 5. SUB Parameter..... 30
  - 5.1.[SHUT] Valve shut-off control (Default Value: 0.5%).....31
  - 5.2.[FULL OPE] Valve full open control (Default Value : 99.7%).....32
  - 5.3.[OUT] Feedback signal settings (Default Value: 4 - 20mA).....33
    - 5.3.1.Position feedback wiring diaphragm.....33
  - 5.4.[SPLIT] Split control settings (Default Value: 4-20).....34
  - 5.5.[ALARM] Set alarm limit (Default Value: 0 – 10%, 90 – 105%).....35
  - 5.6. [IN CALI] – INPUT signal correction (Default Value: factory setting).....36
    - 5.6.1. INPUT 4mA default value setting.....36
    - 5.6.2. INPUT 20mA default value setting.....36
  - 5.7.[PT CALI] – Output signal correction (Default Value: factory setting).....37
    - 5.7.1. OUTPUT 4mA default value setting.....37
    - 5.7.2. OUTPUT 20mA default value setting.....37
  - 5.8. [HART ADD] – HART Communication address (Default Value: 0).....38
  - 5.9.[PST] – Partial Stroke Test (Default Value: OFF).....39
    - 5.9.1.[INTERVA] : Set PST execution cycle.....39
    - 5.9.3. [COMMAND] : Set the change size (Default Value: 10%).....40
    - 5.9.4.[RAMP] : Change amount per second (Default Value : 1.0%).....40
    - 5.9.5. [RESPONS] : Response waiting time (Default Value: '10' seconds).....40

REV	DATE	CHANGE	Made by
1.0	23.09.07		Koh. JS

### 1. General details

#### 1.1. Quick Auto Calibration

Press the MODE button for approximately 5 seconds after the input signal is supplied to begin auto-calibration immediately.

Push **Mo** button 5 seconds, to start auto-calibration.

Press **Mo** button for 5 seconds

REV / DIR ACT : RA / DA setting  
 CEN : Intermediate calculation of sensor  
 ANG : Calculate sensor usage range  
 TUN : TUNE-BIAS operation

- ① The time required for the auto-calibration process varies slightly depending on the size of the control valve and actuator. This usually takes about 2 -3 minutes. However, for large actuators, it takes more time.
- ② If 'MOUNT' is displayed during the auto calibration process, it means that the positioner mount is incorrect. Please reinstall it so that the positioner lever becomes horizontal when the valve is 50% open (CLOSE).



The valve opens/closes during auto calibration. Please check the safety before running.



If you need to stop auto calibration, Press **Mo** button and it will finish and reboot.

For additional information on auto calibration, please refer to 3.5.1 (page 13).

#### 1.2. Display Description

HART Communication

EQ/Quick/User set mode

Control Status

Sensitivity : Low or High

Set Friction mode

NE 107 Alarm

Display Status

PV & Temperature display

Main menu

SV & Parameter display

## 2. Main parameter

### 2.1. Main parameter flowchart

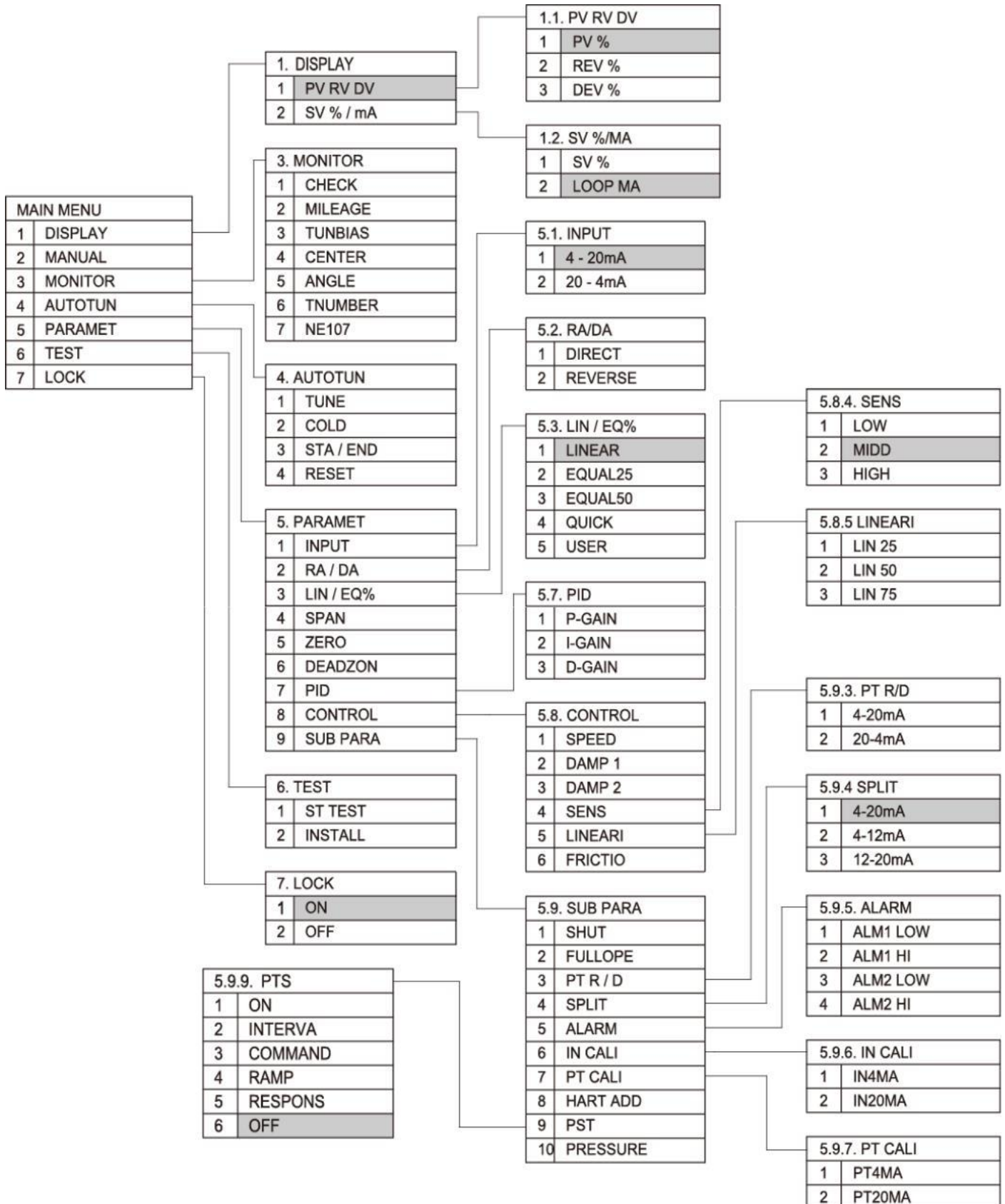

## 2.2. Main Menu Description

Ref.	Parameter	Description	Function
3.1	LOCK	LOCK	Parameter Setting ON/OFF
Ref.	Parameter	Description	Function
3.2	DISPLAY	DISPLAY	Select the content to be displayed on the LCD display
	PV %	PV % value	Current position value displayed in percentage %
	REV %	PV-Reversed % value	Displays the current position value in reverse ( Ex. PV% – 10% → REV% – 90% )
	DEV%	Deviation % value	Display the deviation between the control value and the current position value in percentage %
	SV %	SV % value	Display the current INPUT SIGNAL value as %.
	LOOP MA	SV mA value	Display the current INPUT SIGNAL value in mA.
Ref.	Parameter	Description	Function
3.3	MANUAL	MANUAL	Operate valve manually regardless of the input signal
Ref.	Parameter	Description	Function
3.4	MONITORING	MONITORING	Check status of the positioner
	CHECK	ERROR CHEK	Check error code of the positioner
	MILEAGE	Runtime	Check positioner's usage time
	TUNBIAS	Tune – bias	Check control standard value of the positioner
	CENTER	Position center	Check median sensor values in installed state
	ANGLE	Position angle	Check the overall usage angle in installed state
	TNUMBER	Tune number	Check the number of calibration runs
	NE107	NE 107	Error code confirmation according to NE 107 standard
Ref.	Parameter	Description	Function
3.5	AUTO	AUTO	Auto calibration and initialization
	TUNE	Auto-calibration	Execute auto calibration
	COLD	Re-boot	Positioner restart
	STA/END	START-END calibration	0 / 100% position reset
	RESET	Reset	Reset to factory default
Ref.	Parameter	Description	Function
4	PARAMET	Parameters	Refer to next page
Ref.	Parameter	Description	Function
3.6	TEST	TEST MODE	Valve and installation condition testing
	ST TEST	Step test	Valve step testing
	INSTALL	Install test	Installation status of the positioner checking

## 2.3. Parameter

### 2.3.1. Main Parameter

Ref.	Parameter	Description	Function	Default Value
4.2	INPUT	Input signal	Control direction change according to input signal	4...20mA
4.3	RA/DA	RA / DA Acting	Reverse acting/direct acting setting	Auto
4.4	LIN / EQ%	Characteristic	Linear, EQ25, EQ50, Quick, User set	Linear
4.5	SPAN	Span adjustment	50.0...100.0%	100%
4.6	ZERO	Zero adjustment	0...10.0%	0%
4.7	PID	PID Gain	PID control value setting	Auto
4.8	CONTROL	Control parameters	-	•
4.9	DEADZON	Signal dead band	0...10.0%	0.3%
5	SUBPARA	Sub-Parameters	-	•

### 2.3.2. CONTROL Parameter

Ref.	Parameter	Description	Function	Default Value
4.8.1	SPED	Response speed	0...995	995
4.8.2	DAMP 1	1st Control limit	1st control limit	Auto
4.8.3	DAMP 2	2st Control limit	2st control limit	Auto
4.8.4	SENS	Sensitivity	Sensitivity setting	MIDD
4.8.5	LINEARI	Linearization	Linearization Compensation	-
4.8.6	FRICTIO	Friction control mode	Friction control mode	None

### 2.3.3. SUB Parameter

Ref.	Parameter	Description	Function	Default Value
5.1	SHUT	Shut-off	Forced closing section setting	0.5%
5.2	FULLOPE	Full-open	Forced opening section setting	99.7%
5.3	PT R/D	Output signal RA/DA	Direction setting of output signal	4...20mA
5.4	SPLIT	Split range	Split control settings	4...20mA
5.5	ALARM	Software limit low, high	Alarm limit settings	0...10%, 90...105%
5.6	INCALI	Input signal calibration	4-20mA input signal correction	Factory setting
5.7	OUTCALI	Output signal calibration	4-20mA output signal calibration	Factory setting
5.8	HARTADD	HART polling address	0...63	0
5.9	PST	Partial stroke testing	Partial stroke testing settings	OFF

## 3. Main parameters settings

### 3.1. [LOCK] LOCK ON / OFF

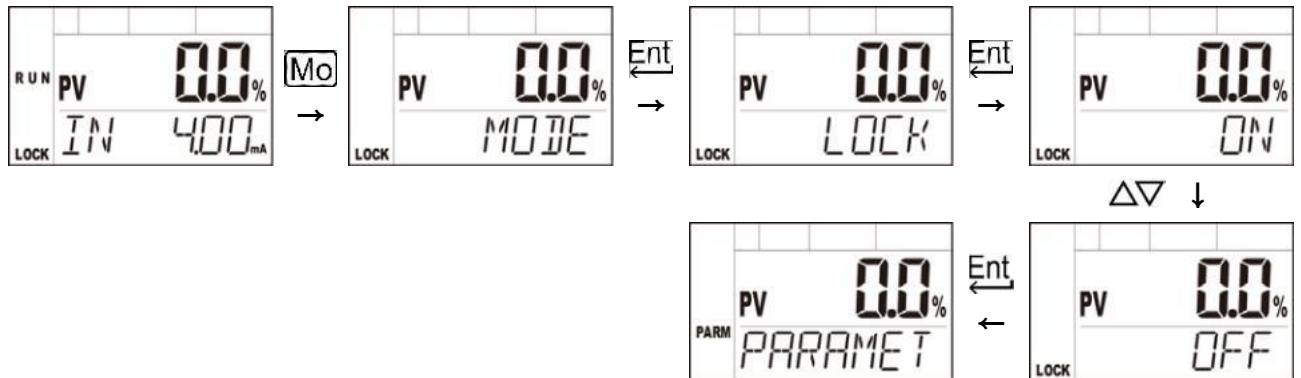

[LOCK] is a function that prevents manipulation of the positioner's functions (parameters). To operate the positioner, you can change it to "LOCK -> OFF" and then operate it.

When you exit "MODE", "LOCK->ON" is automatically activated.



- ① LOCK ON : Protects all saved settings.  
When it is ON, all parameters cannot be checked or changed.
- ② LOCK OFF : When reading or changing selected parameters and saved settings , be sure to LOCK must be set to OFF.
- ③ Quick auto calibration can be set immediately without turning LOCK to OFF.
- ④ Positioner control is not related to LOCK setting.

### 3.2. [DISP] Change display value

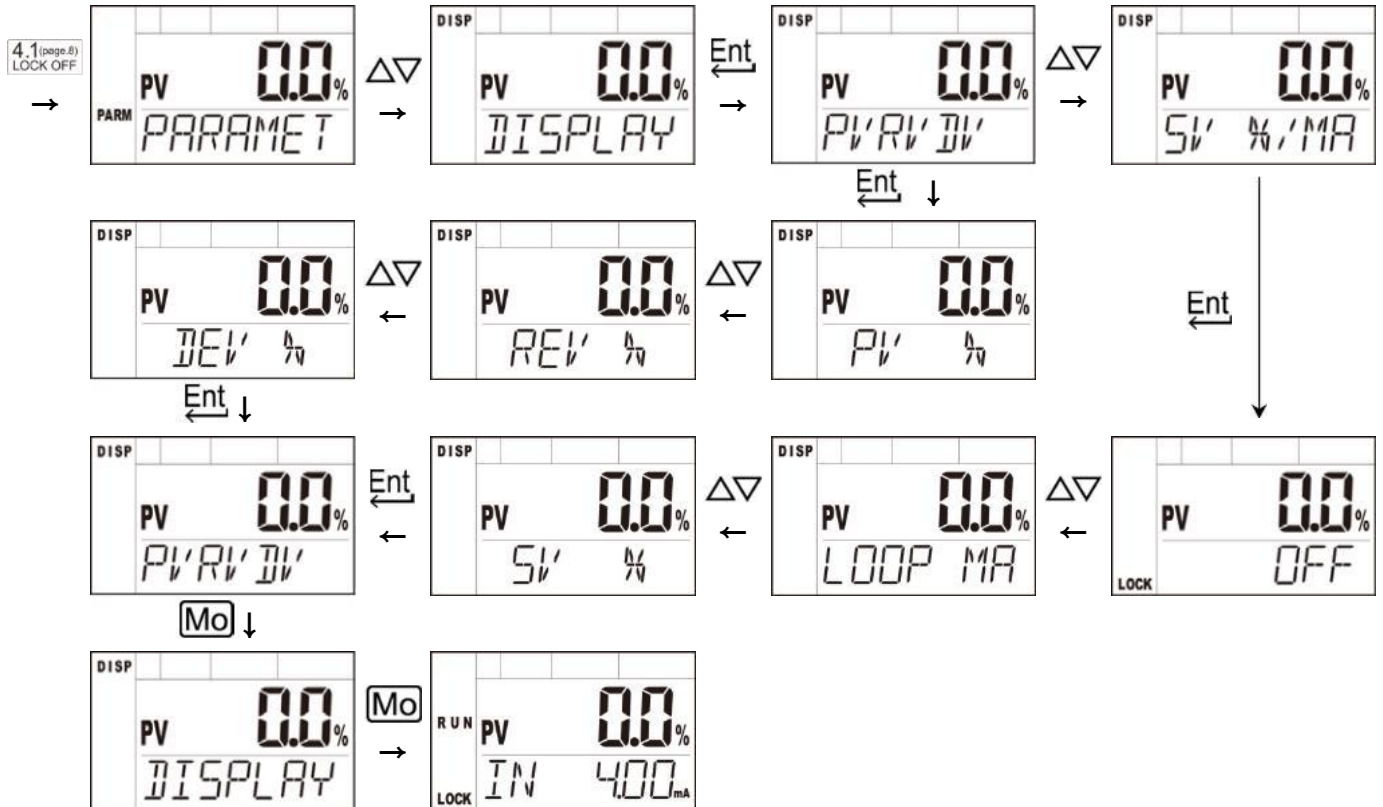

- **PV RV DV** : A function that determines how to express the position value of the middle display section.
  - 1) PV % : Current valve position value expressed in %
  - 2) REV % : Reverse expression of the current valve position value
  - 3) DEV % : SV (Input signal) – Expresses the deviation value of PV

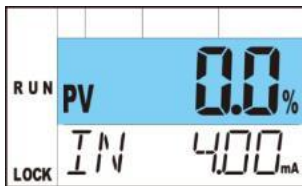

PV %

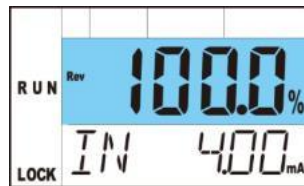

REV %

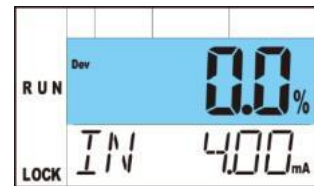

DEV %

- **SV % / mA** : A function that determines how to express the SV value in the display section at the bottom of the display.

- 1) SV % : Input signal expressed as % value
- 2) Loop mA : Input signal expressed as mA value



SV %

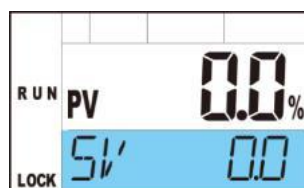

Loop mA

## 3.3. [MAN] Manual Mode

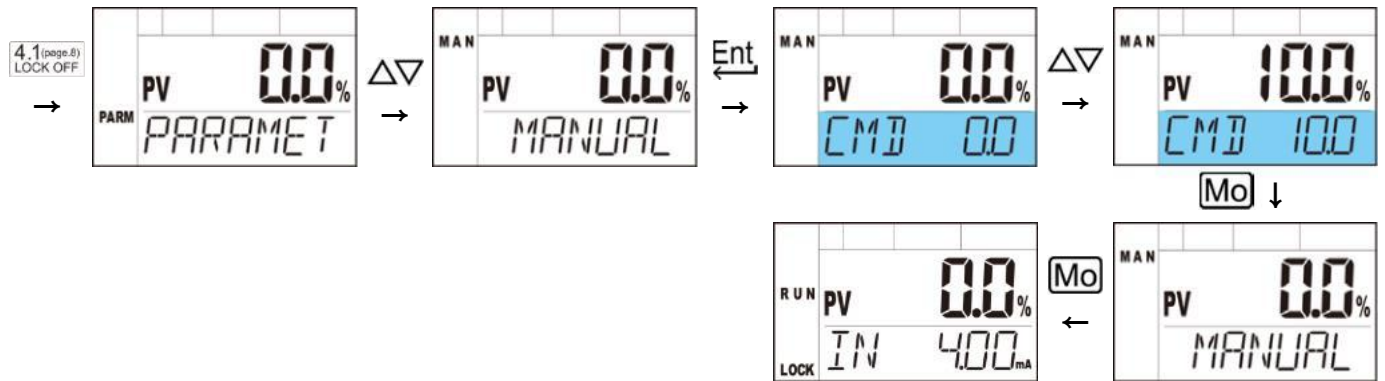

This is a function to manually operate the valve using button operation.

If trial run or random operation is required using this function, operation is possible regardless of external signals.



- ① In situations where the function is active, it will not respond to external signals. Therefore, please check first the possibility of any issues that may arise during operation
- ② The MANUAL function does not end automatically. When the test is complete, press the **Mo** button.

### 3.4. [MON] Monitoring Mode

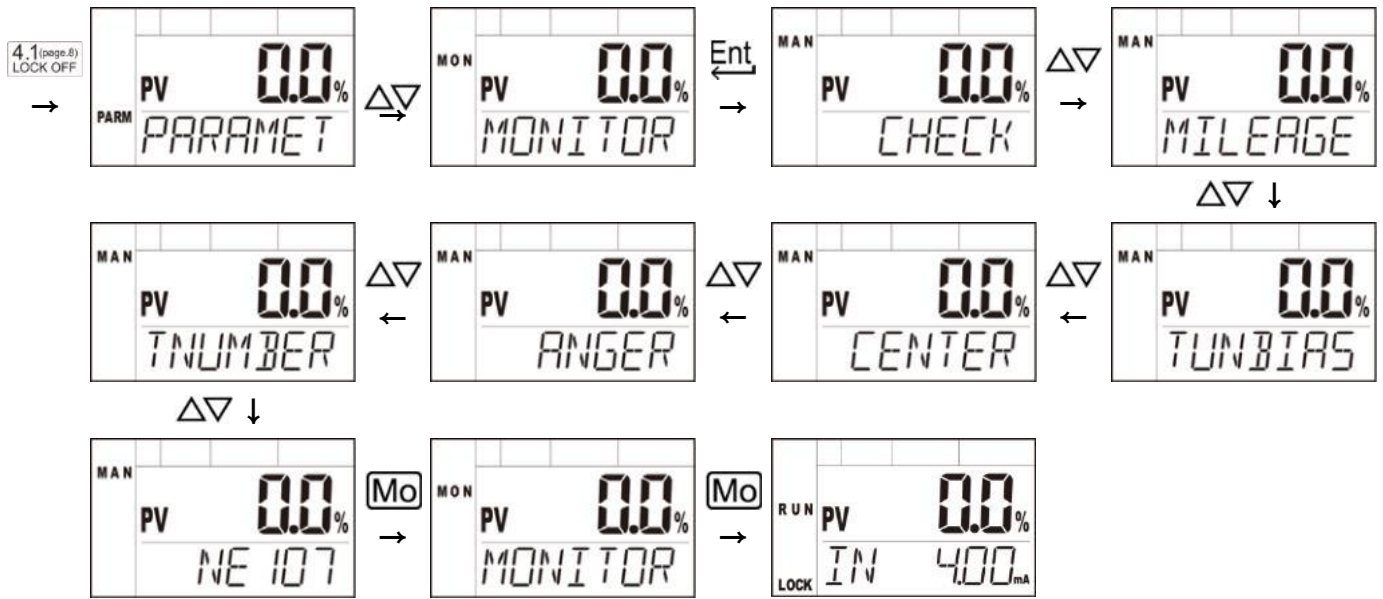

This is a menu to check various information stored in the positioner.

The MONITORING menu can be accessed even without turning LOCK to OFF.

- |            |  |
|------------|--|
| 1) CHECK   | : Indicates the problem as a result of self-examination.   |
| 2) MILEAGE | : Indicates the period of use of the positioner            |
| 3) TUNBIAS | : Displays the basic control value                         |
| 4) CENTER  | : Indicates the median value of the angle used.            |
| 5) ANGLE   | : Indicates the total angle of use.                        |
| 6) TNUMBER | : Displays the number of auto-calibration execution times. |
| 7) NE107   | : Displays NE107 examination results.                      |

### 3.5. [AUTO] Auto-Calibration Mode

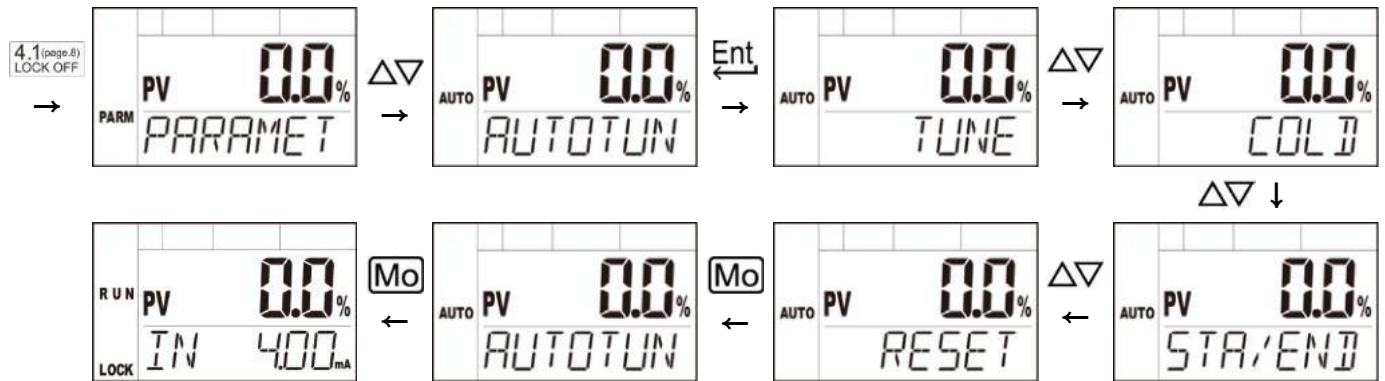

- 1) TUNE : Auto Calibration
- 2) COLD : Restart
- 3) STA/END : Zero reset
- 4) RESET : Factory reset

There are two methods of calibration, and the calibration details are as follows.

	Start positioner	End positioner	PID & Tune-BIAS
TUNE	○	○	○
STA/END	○	○	X



If you press the **Mo** button on the basic screen for 5 seconds, "TUNE" will run automatically.

### 3.5.1. [TUNE] Auto Calibration

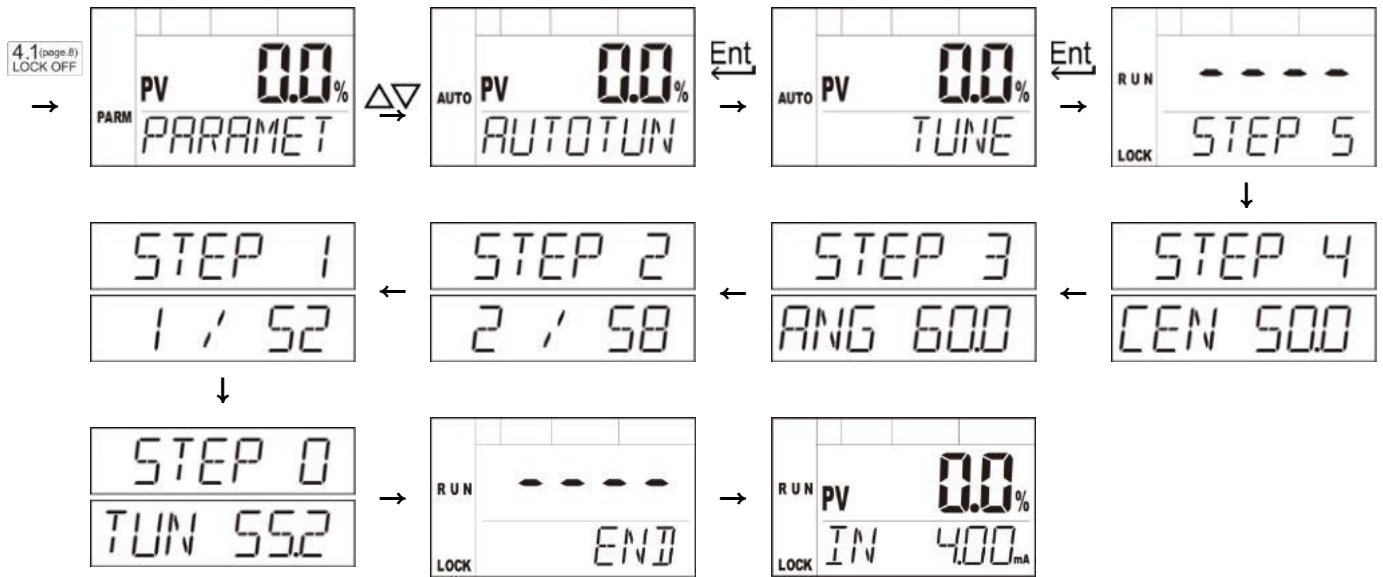

Auto Calibration is separately by step 5~0 and each step is as follows.

Step	Description	Range
STEP 5	1. Check Type of Reverse / Direct acting 2. Check End position	-
STEP 4	1. Check Start position 2. CEN(Sensor center) calculation and notation	40% < CEN < 60.0% (Recommended value : 50%)
STEP 3	1. ANG(sensor angle) calculation and notation	10% < ANG < 80% (Recommended value : 50%)
STEP 2	1. Check Valve opening	30% < STEP2 < 70%
STEP 1	1. Check Valve closing	30% < STEP1 < 70%
STEP 0	1. Tune-bias calculation	30% < TUN < 70%

The time required for the auto-calibration process varies depending on the size of the control valves and actuators, and generally will take approximately 2 to 3 minutes. For larger actuators, it will take more time. If the positioner is installed incorrectly on the valve, a "MOUNT" error will occur and normal auto calibration will not proceed. In this case, please refer to 'Installation' and re-install.



- ① When released from the factory, it is set to RA (reverse acting). Even if the airline is accidentally connected to DA (direct acting), auto calibration automatically detects this and executes it as DA (direct action).
- ② If there is no movement of the valve during auto-calibration, check the settings of the supply air pressure or other accessories.
- ③ Execution is possible regardless of the input signal (mA).

### 3.5.2. [RESER] Parameter initialization

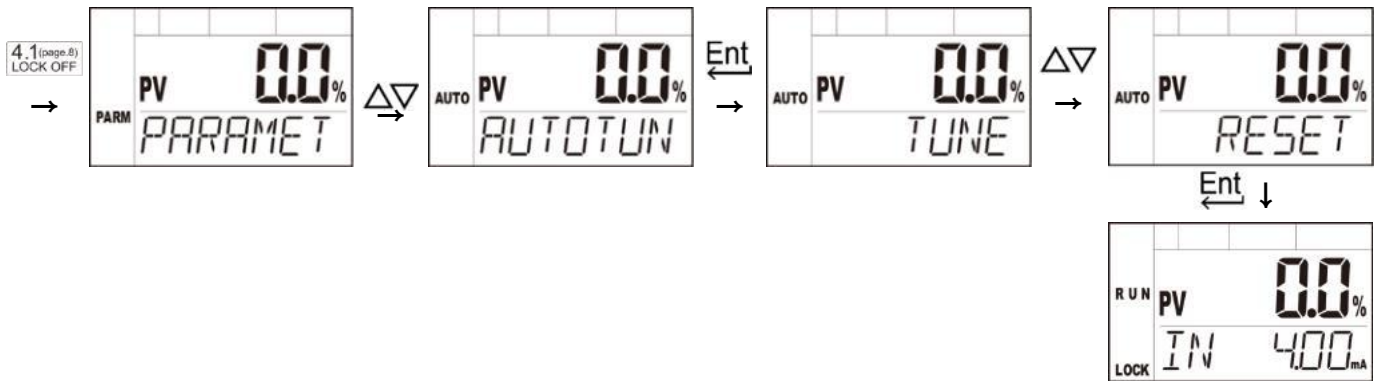

Initialize all parameters to factory default values.  
After initialization, please run auto-calibration again.



All settings will be initialized, so please run it under ensuring safety.

### 3.5.3. [STA/END] Readjust START & END Positions

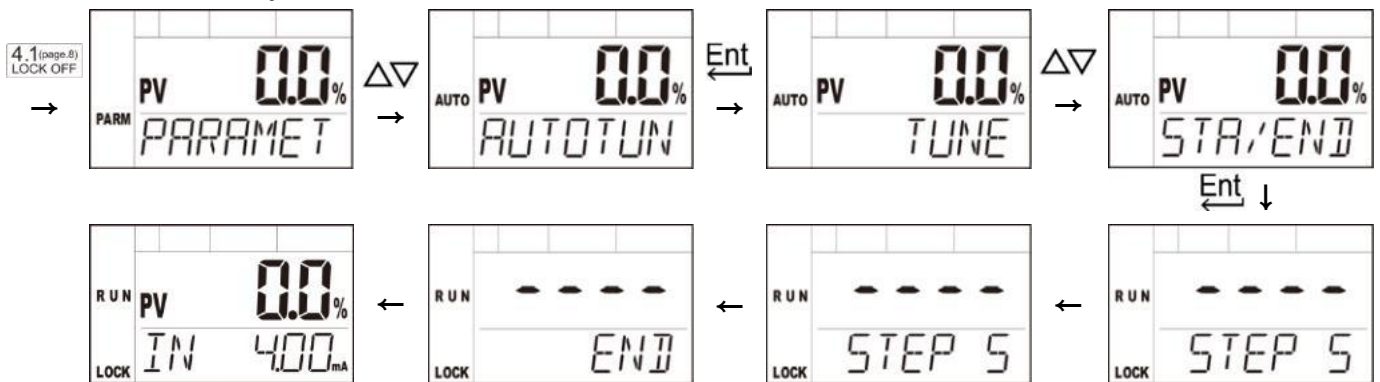

When the positioner's Start & End positions are wrong, the control value and the user's separate settings are not changed, and only the ZERO/SPAN value is readjusted.



If unstable control occurs, please run auto-calibration (TUNE) and reset the PID & BIAS values.

### 3.5.4. [COLD] Restart

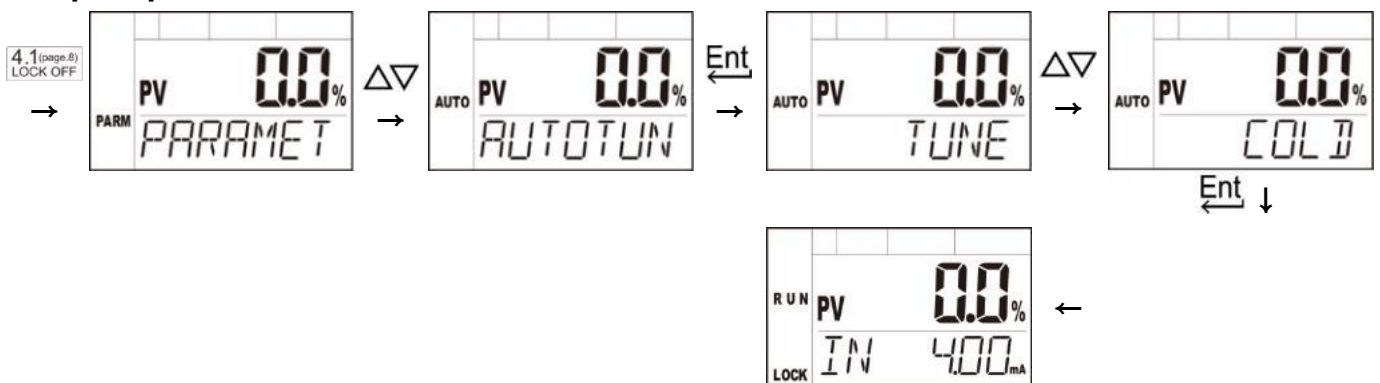

This is a parameter to restart the positioner.

### 3.6.[TEST] Test Mode

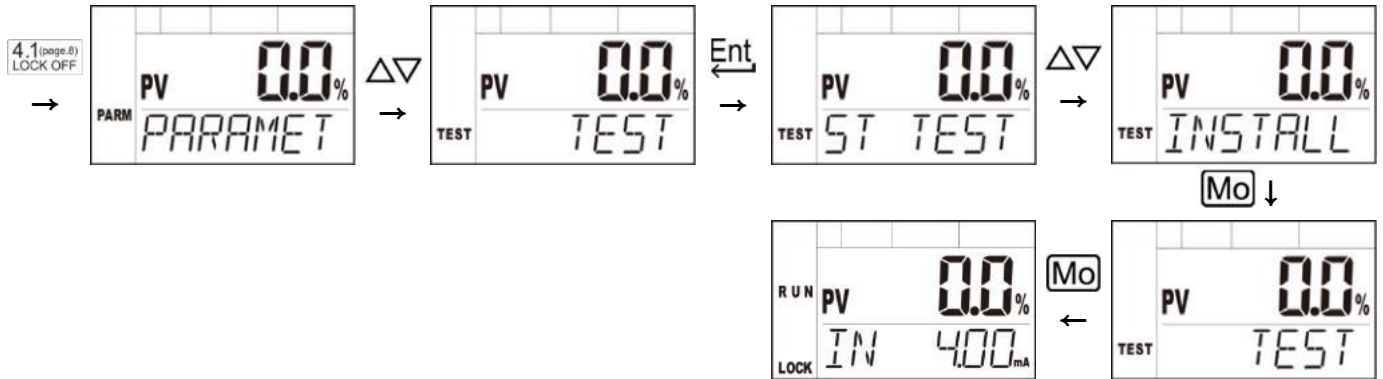

- 1) ST TEST : Valve Test Function
- 2) INSTALL : Function to check the installation status of valve & positioner.

#### 3.6.1. [ST TEST] Valve test

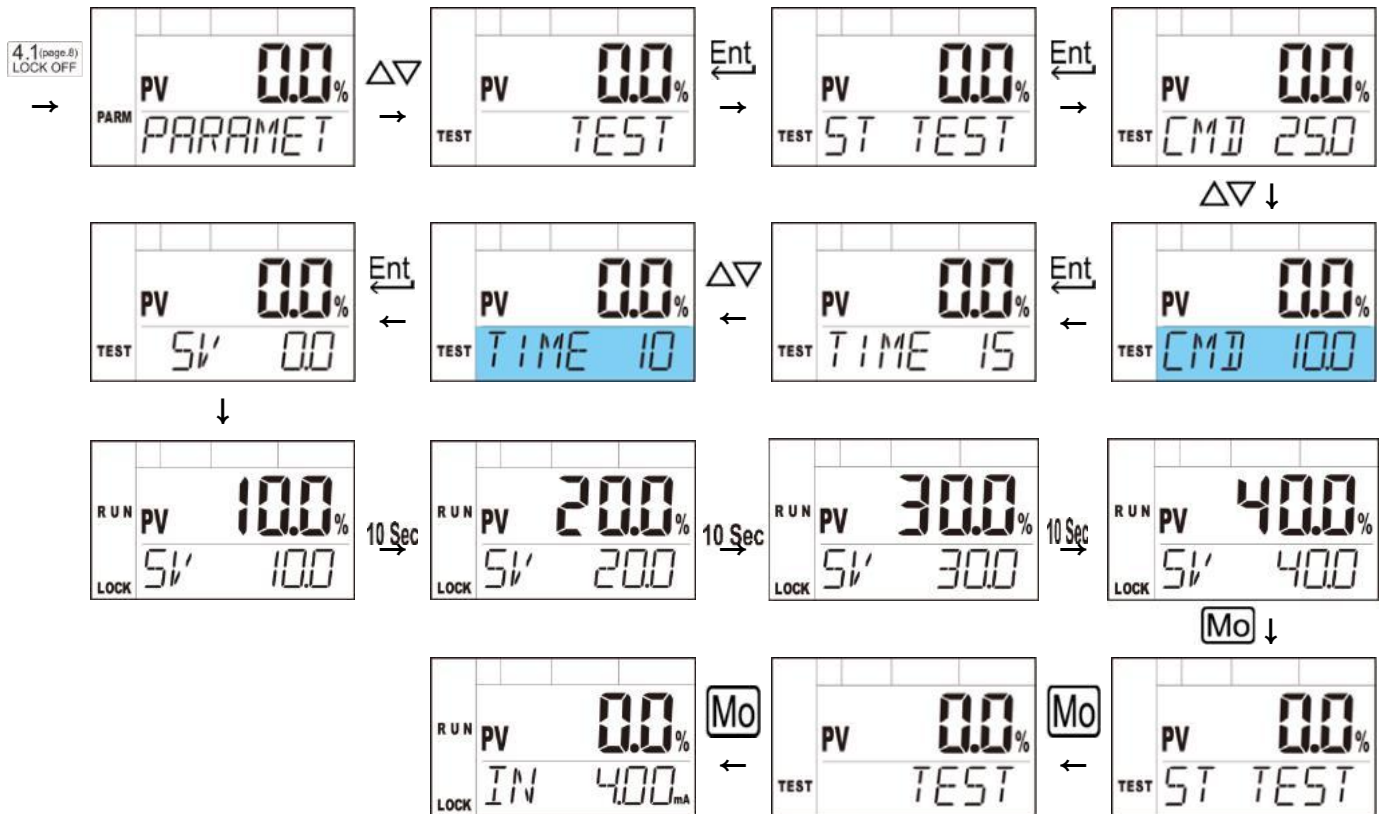

This is a function that increases or decreases the "SET COMMAND" amount with the "SET TIME" cycle.

If you use the settings above, the control value increases / decreases by 10% every 10 seconds.

Regardless of SET TIME, you can immediately increase/decrease the control value by "SET COMMAND" by pressing the UP/DOWN button.



- ① Since it does not respond to external signals in the situation where the function is activated, we recommend that you first check for possible problems when operating it.
- ② The VALVE TEST function does not end automatically. Please press the **Mo** button to exit.

### 3.6.2. [INSTALL] Check installation status.

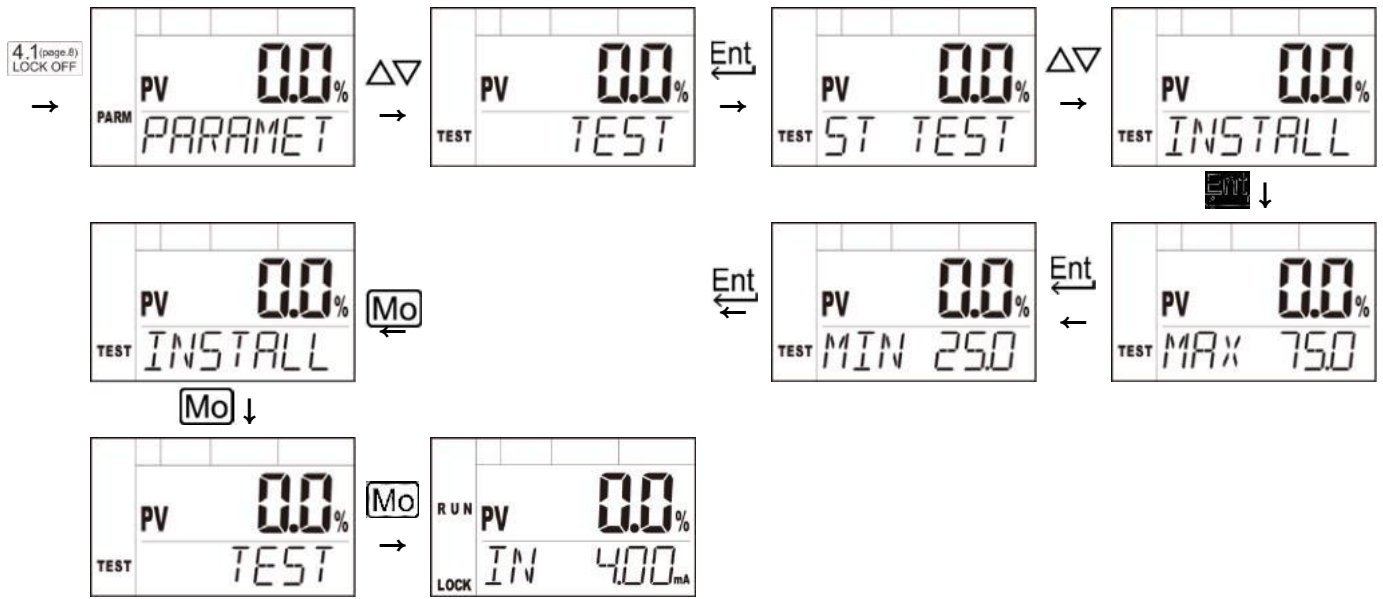

This is a function to check the positioner installation status, and is expressed based on the median value of the sensor (50.0).

Please wait until there is no movement in the UP or DOWN angle and then press ENT.

The closer the CENTER value is to 50.0, the better.



If the sensor's usable range is exceeded, "FAULT" will be displayed.  
The valve position must be readjusted and then checked.



Precision improves when using a larger angle.  
Please be careful not to exceed the range of MAX > 80, MIN < 20.

Asv-s-a110p

## 4. Parameter

### 4.1. Parameter Flow Chart

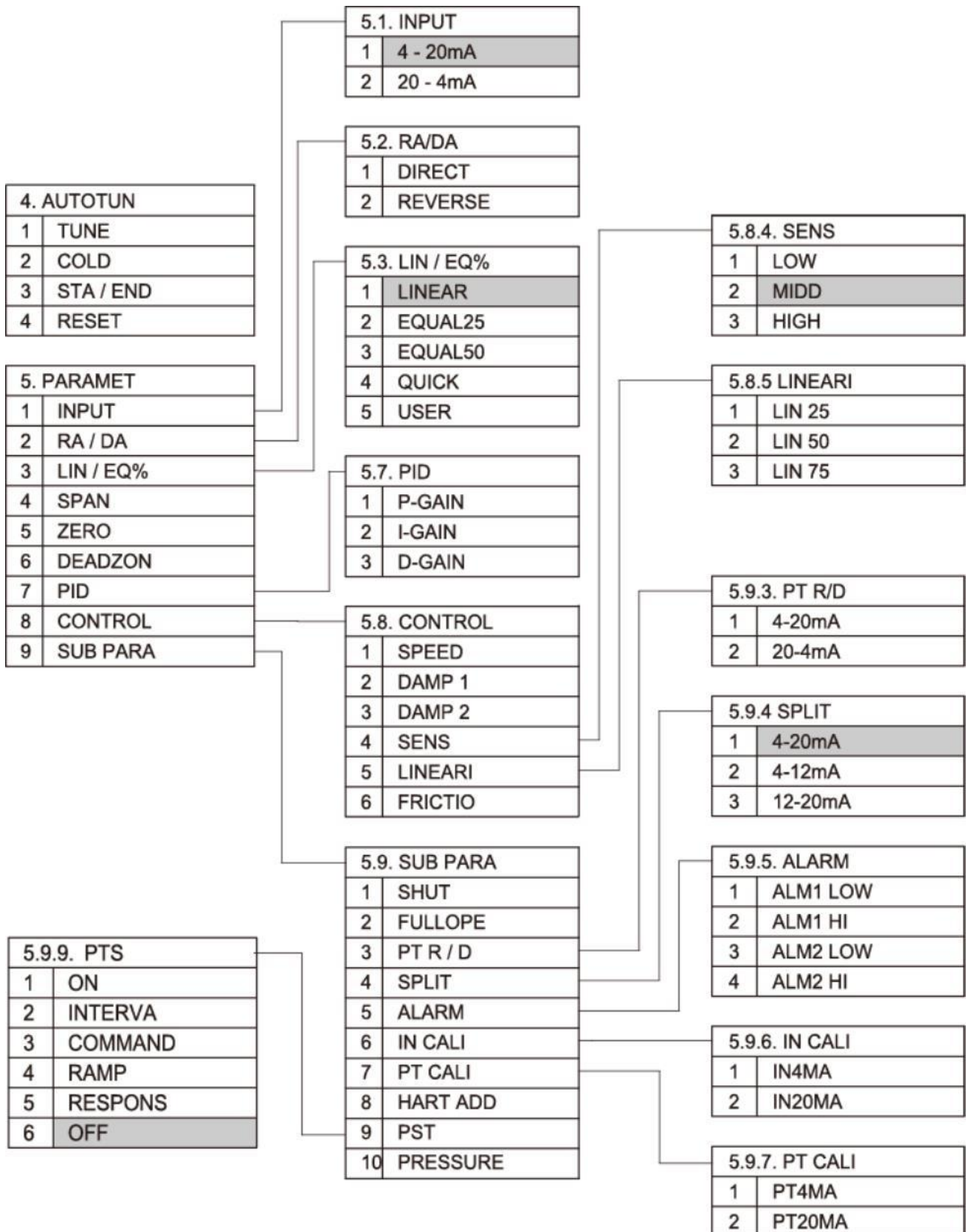

### 4.2. [INPUT] Change input signal (Default Value: 4-20mA)

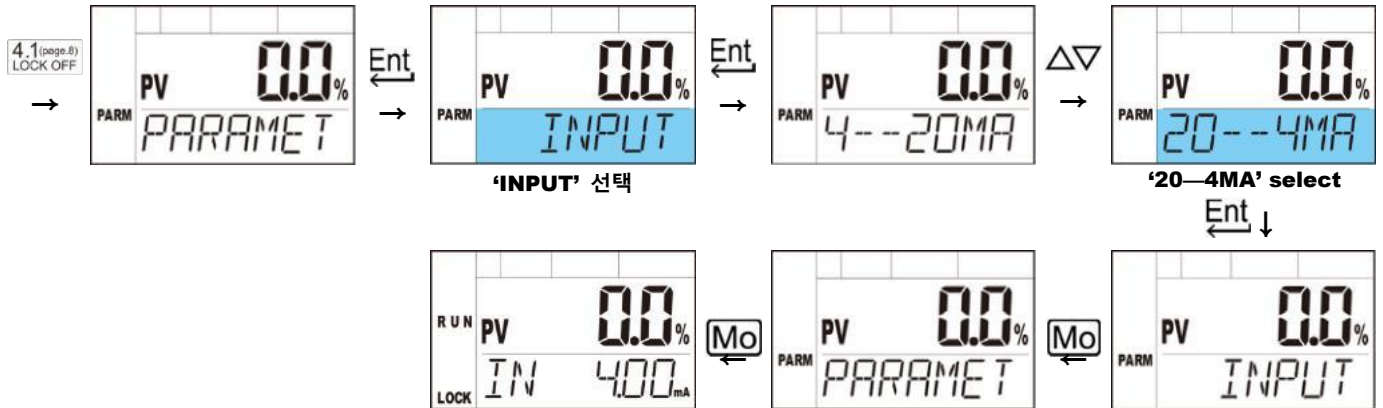

This function switches the control position status when 4mA is input.

When controlling the valve to 0% when inputting 4mA

➔ When changing to 20-4 mA, the valve control position changes to 100% when 4mA is input.

When the valve is controlled at 100% when 4mA is input.

➔ If you change it to 20-4mA, the valve control position is changed to 0% when 4mA is input.



**Please note that In case of SIGNAL FAIL, the pressure of OUT1 is maintained at '0 bar'**

**regardless of the 'INPUT' parameter setting.**

### 4.3. [RA/DA] Select Direct acting (DA) / Reverse acting (RA) (Default Value: Automatic setting)

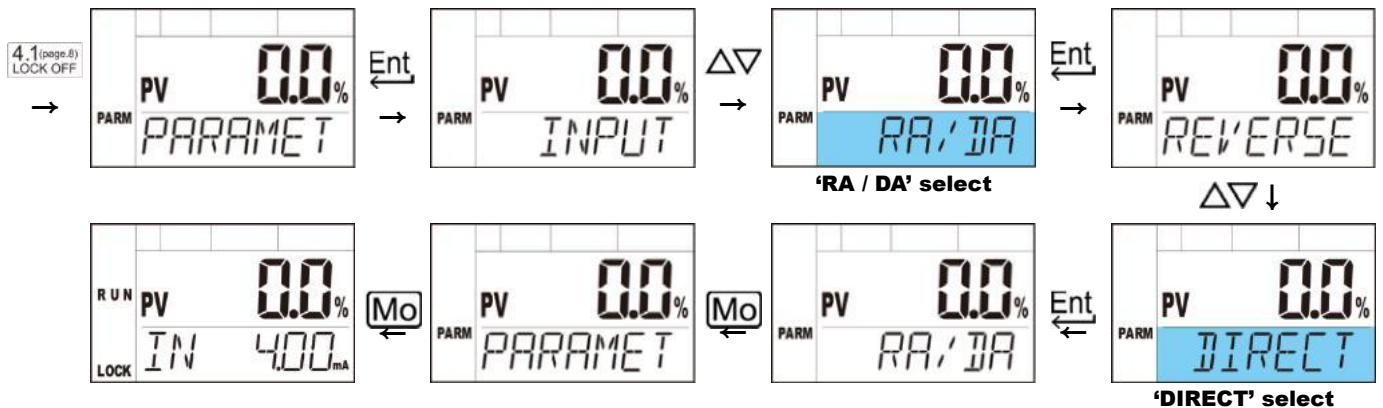

RA/DA is automatically detected and set during auto-calibration, and no separate adjustment is required.



**If you change the settings arbitrarily without any changes to the actuator and piping, only OPEN-CLOSE is possible.**



**If the operation according to the signal needs to be reversed, 4.2 [INPUT] must be**

**changed. If you need to reverse the display indication value, you must change 3.2 [DISPLAY].**

**If the output signal needs to be reversed, 5.3 [PT R/D] must be changed.**

4.4. [LIN/EQ%] Change Linear, EQ%, Quick, User set operation characteristics (Default Value: Linear)

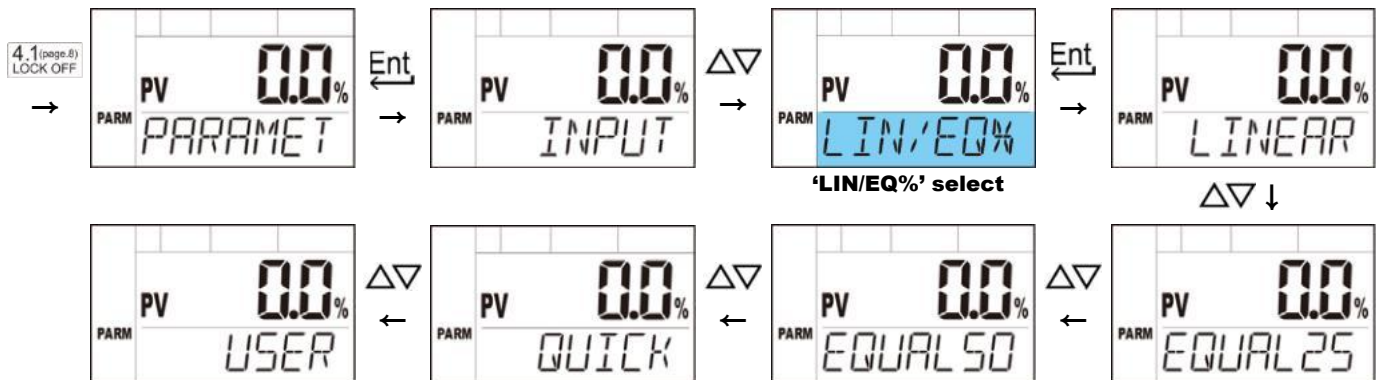

Valve operation characteristics can be changed to Linear, EQ 25%, EQ 50%, Quick Open, and User set.

### 4.4.1. [LIN/EQ/QUICK]

The control characteristics of Linear, EQ 25%, EQ 50%, and Quick Open are shown in the graph below.

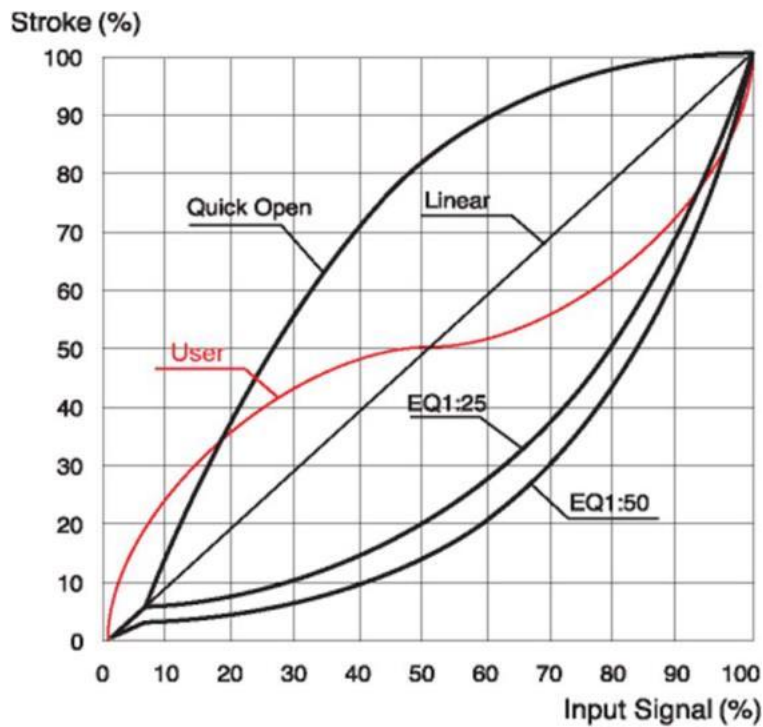

### 4.4.2. [USER] User characteristic

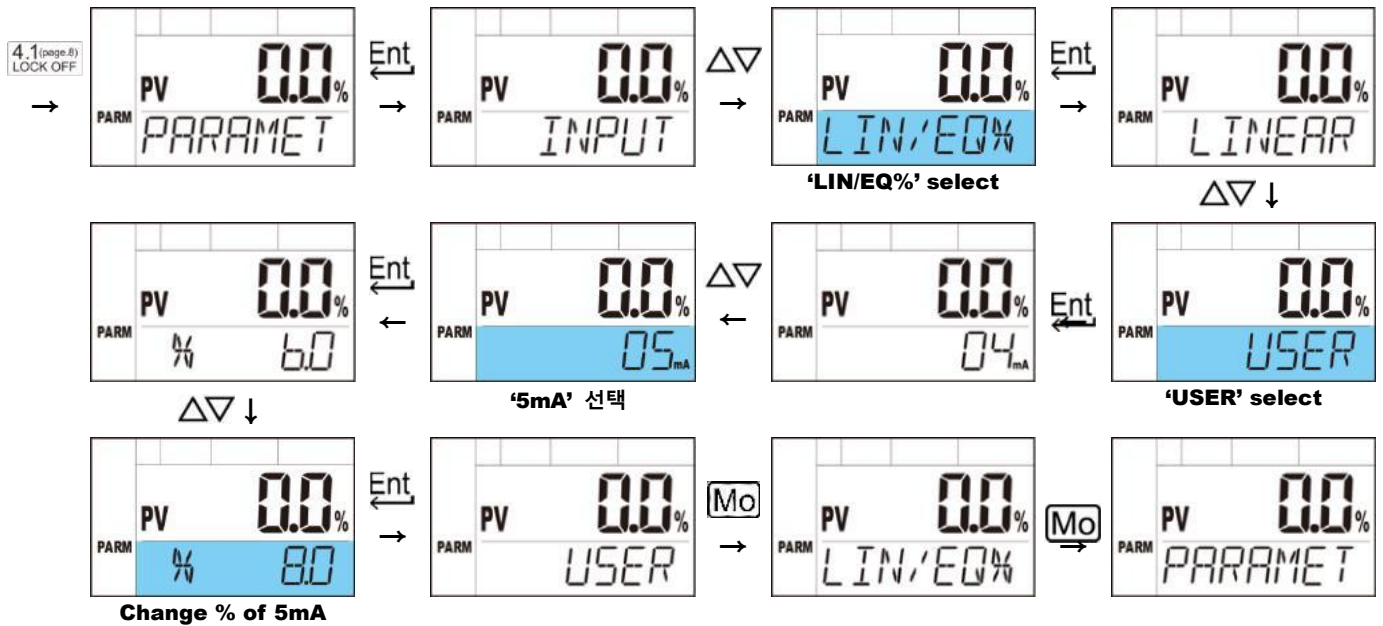

You can create the control curve you want by adjusting the position value every 1mA from 4mA to 20mA.

#### Example 1)

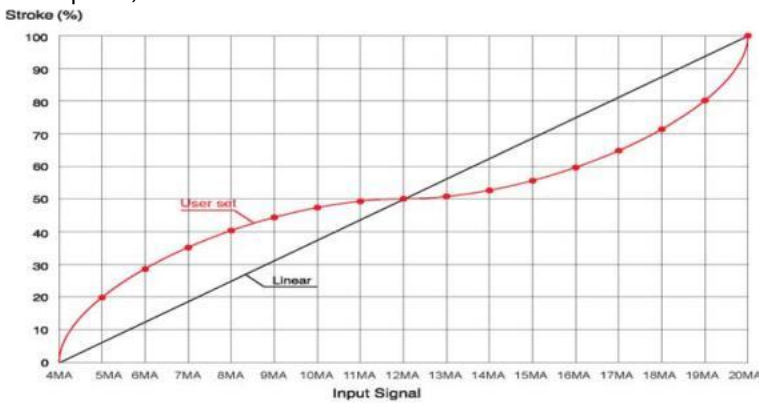

Point	Parameter	User Set Value Linear (%)	Ex-1 Ex-2	
			Valve Opening% (set value)	
1	4mA	0	0	50
2	5mA	6	20	30
3	6mA	13	29	20
4	7mA	19	35	15
5	8mA	25	40	10
6	9mA	31	45	6
7	10mA	38	48	4
8	11mA	44	49	2
9	12mA	50	50	0
10	13mA	56	51	3
11	14mA	63	52	7
12	15mA	69	55	11
13	16mA	75	60	20
14	17mA	81	65	30
15	18mA	88	71	43
16	19mA	94	80	60
17	20mA	100	100	100

#### Example 2)

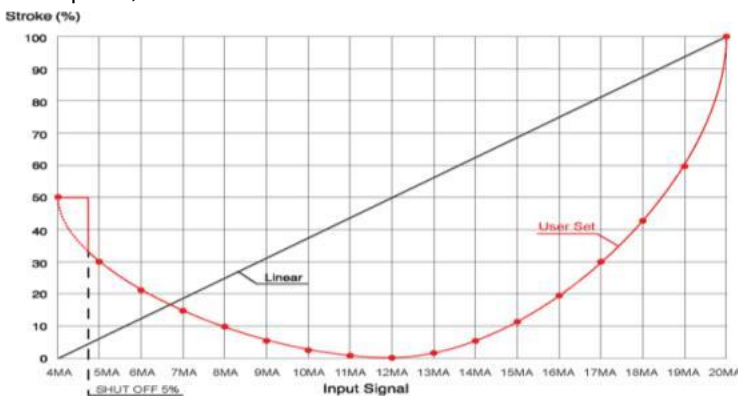

#### NOTES

User's basic setting value is the Linear characteristic value.

5mA means % corresponding to 5mA of user set characteristics.

To display user set characteristics, each mA value (4mA~20mA) must be entered.

※ When using the SHUT OFF function, the value set at 4mA like Ex-2) is maintained as much as the SHUT OFF setting value.

After the SHUT OFF setting section, the set user set characteristics are followed. (SHUT OFF default is 0.1%)  
In the case of Ex-2), SHUT OFF 5% is given, so 50% is maintained at 4.48mA, and then SHUT OFF is released and the user set curve is reached.

### 4.5. [SPAN] Change span value (Default Value: 100)

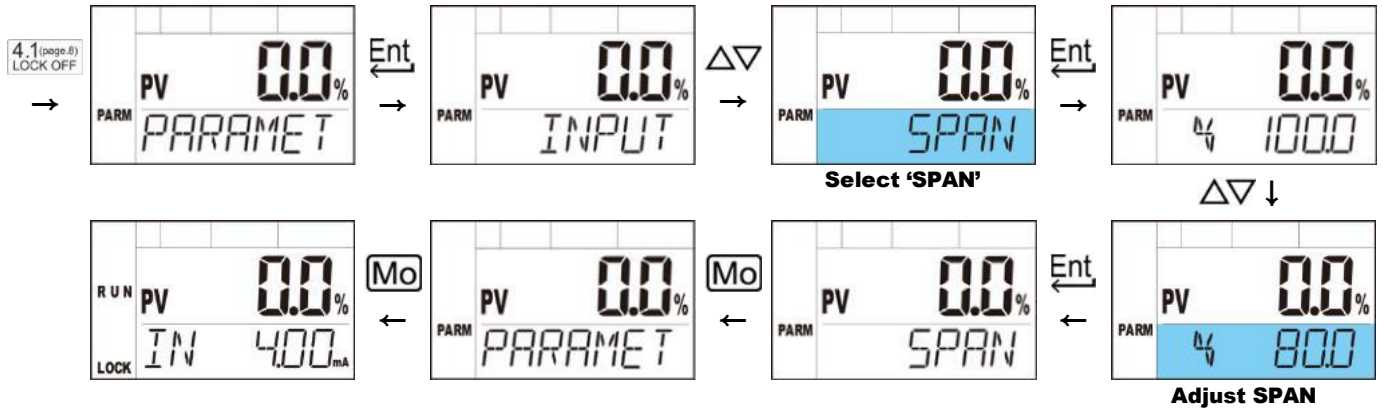

This function adjusts the maximum opening amount of the valve. When the default value is SPAN-100%, when 20mA is input, the entire supply air is delivered to the valve.

For linear type actuators, the SPAN value can be adjusted to match the valve indicator. You can adjust it by reducing the SPAN value while looking at the valve indicator.

When the SPAN value is adjusted to 80.0%, the range from 0.0% to 80.0% is controlled for the 4-20mA signal.

4 mA – 0% displayed value (0% actual position), 20 mA – 100% displayed value (80% actual position)



- ① Before changing the settings, a 20mA input signal must be supplied.
- ② When you press DN button, it decreases by 0.1%, and when you press and hold it, it decreases quickly.

### 4.6. [ZERO] Change zero (Default Value: 0)

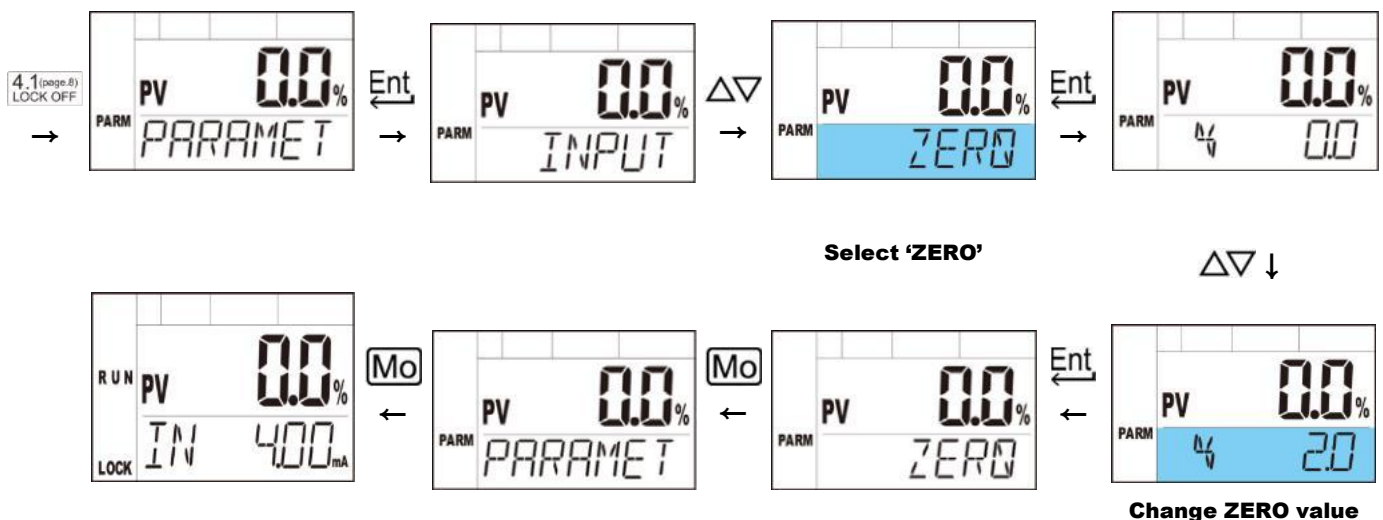

This is a parameter that adjusts the control start point of the valve, which allows the valve to be opened by the set value without closing the valve to the PV maximum when it is 4 mA or 0%.

When the ZERO UP value is adjusted to 2.0%, the range from 2.0% to 100.0% is controlled for the 4-20mA signal.

4 mA – 0% of displayed value (2.0% of actual position), 20 mA – 100% of displayed value (100% of actual position)



### 4.7.2. [I-GAIN] Integral Gain

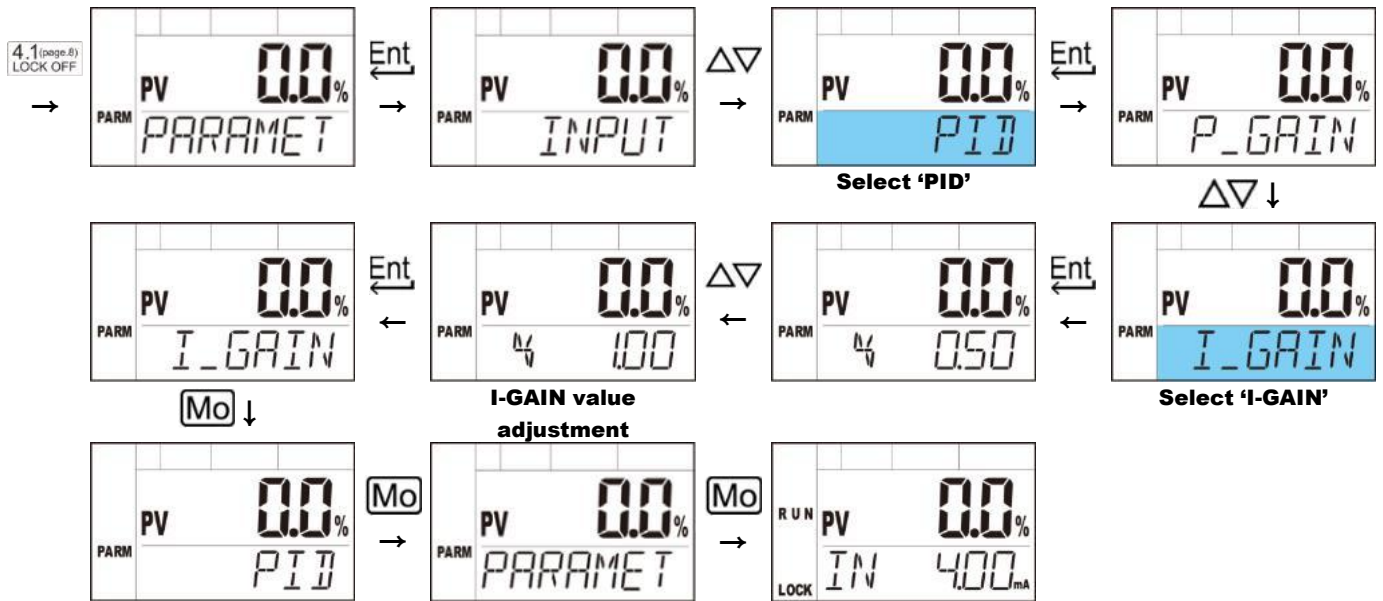

However, if the friction of the valve is strong or the valve stick is severe, continuous hunting may occur due to I-Gain compensation. In this case, please increase the I-Gain value to suit the valve situation.



I-GAIN is set to 0.5% by default, and automatically changes to 1.0~2.5% if hunting occurs during auto-calibration. If I-GAIN is set to 0.0%, integral compensation is not performed.

### 4.7.3. [D-GAIN] Differential Gain

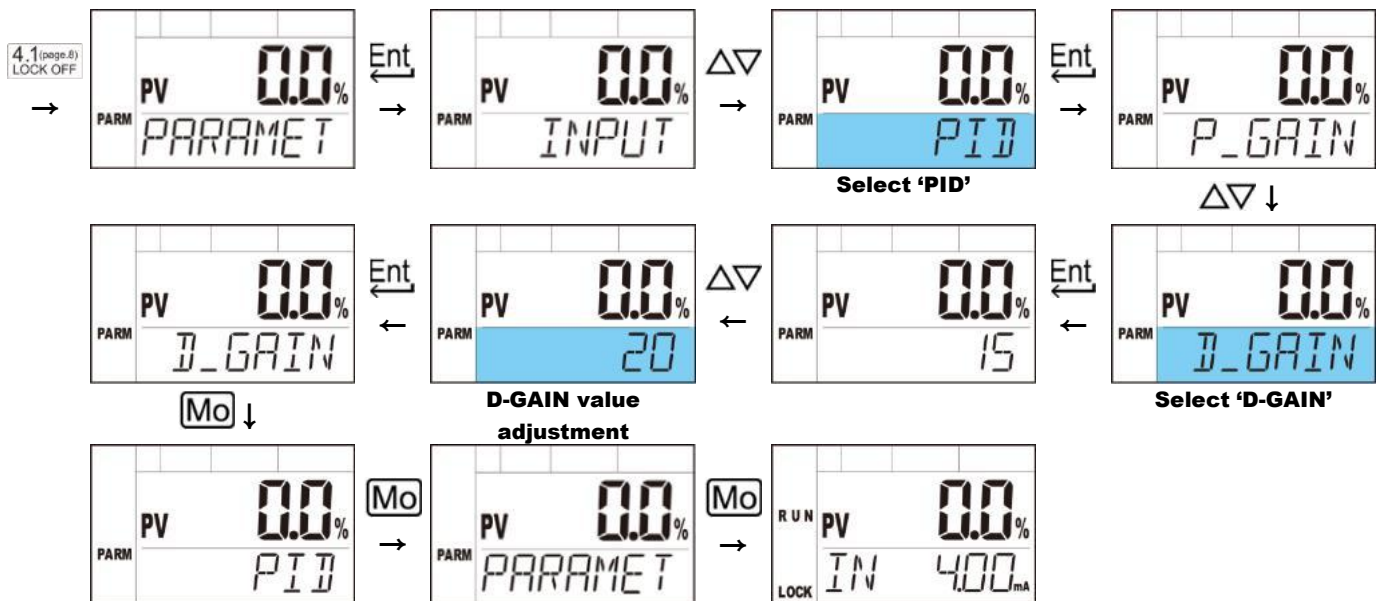

It is automatically set through the auto-calibration process, so there is no need to change it separately.

The D-gain is a parameter that performs differential integration, reducing the control value to prevent overshoots and undershoots.

If the valve is small, the quick action will cause overshoots and undershoots. This can be reduced by increasing the D-Gain value. If the valve is large, slow motion can cause severe deceleration before the target is reached. This can be mitigated by reducing the D-Gain value.

### 4.8.[CTRL] – Control Setting Parameter

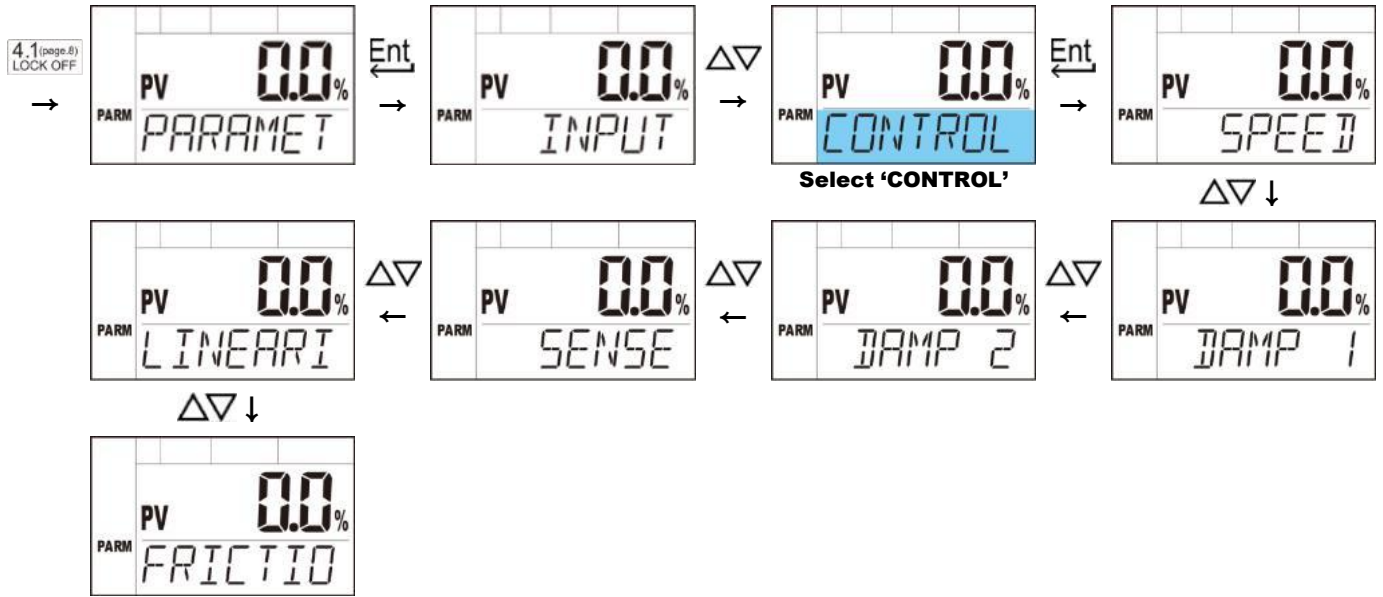

This is a parameter related to control. CONTROL Parameters include speed settings, control limit settings, sensitivity settings, linearization, and friction mode settings.

#### 4.8.1. [SPEED] – Adjust operation speed (Default Value: 995)

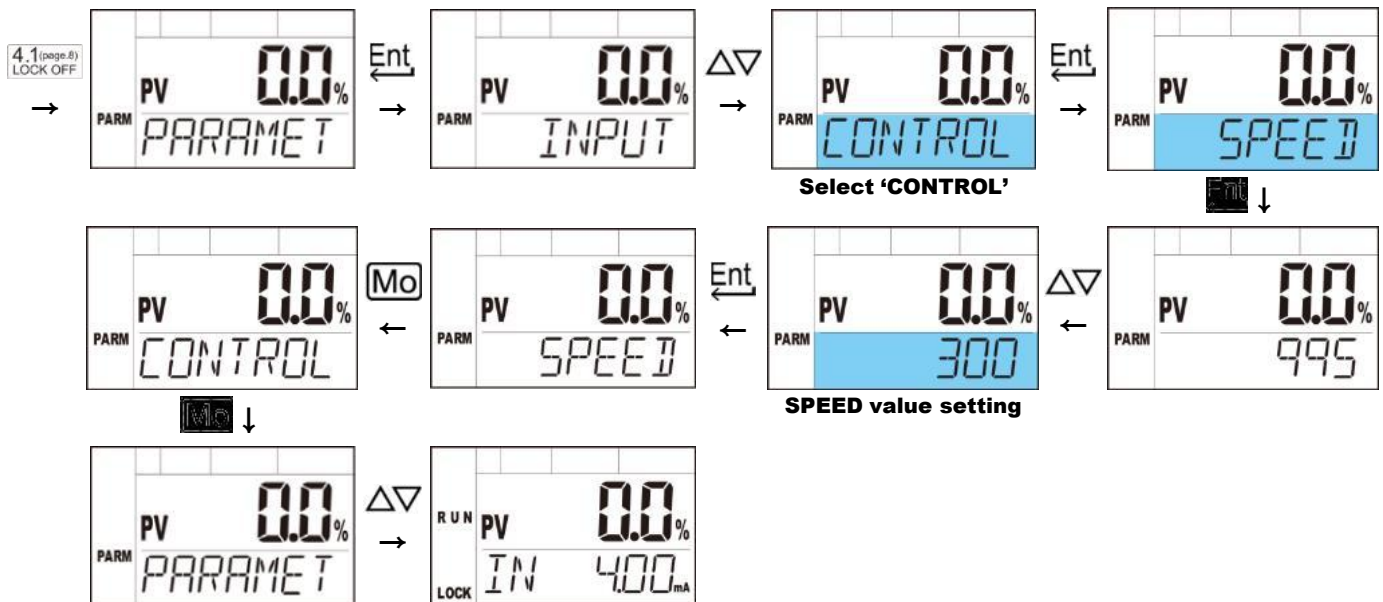

You can adjust the operating speed of the control valve and actuator (Min: 1, Max: 995)

It is set to the default maximum speed, and the lower the value, the slower the control speed becomes.



**SPEED Parameter is used to reduce the control speed. When control is desired at a faster speed,**



**please use AIR VOLUME BOOSTER.**

In case of signal failure, the deceleration function adjusted by parameters is not supported, so it opens or closes at the default speed. If deceleration is required even when signal fails, attach a speed controller or orifice.

## 4.8.2.[DAMP 1] – Maximum control amount (Default Value: automatic setting)

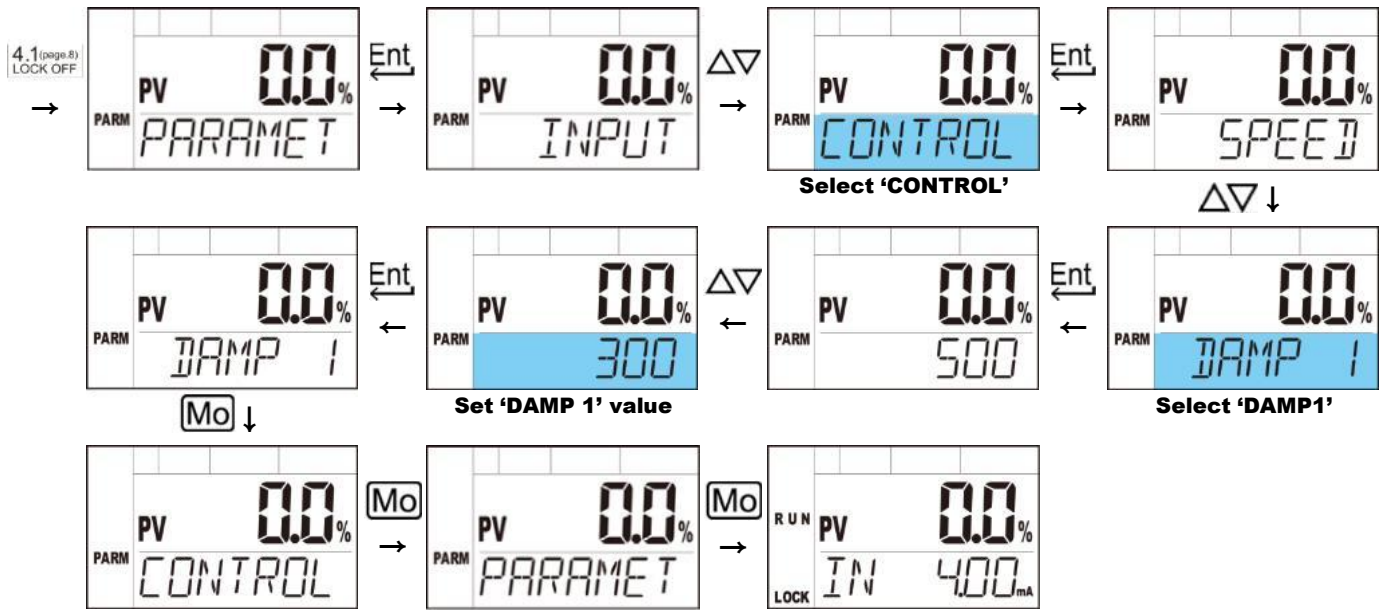

'DAMP 1' is automatically set during auto-calibration.

DAMP 1 (maximum control amount): maximum control amount

DAMP 2 (maximum section control amount): Maximum control amount used in the range (INPUT SIGNAL  $\pm$  3%)

PID control amount > 'DAMP 1' control amount = 'DAMP 1' maximum control amount

PID control amount < 'DAMP 1' control amount = PID control amount

If you increase the 'DAMP 1' setting value,

- ➔ Because the PID control amount can be greatly reflected, responsiveness and control speed become faster.
- ➔ Hunting may occur due to sensitive control.
- ➔

If you lower the 'DAMP 1' setting value,

- ➔ Because the PID control amount is reflected in a small amount, responsiveness and control speed become slow.
- ➔ If hunting occurs or if the value is lowered for a small valve, stable control is possible.



**When adjusting DAMP 1, it is recommended to adjust DAMP 2 as well.**

### 4.8.3. [DAMP 2] – Maximum section control amount (default: automatic setting)

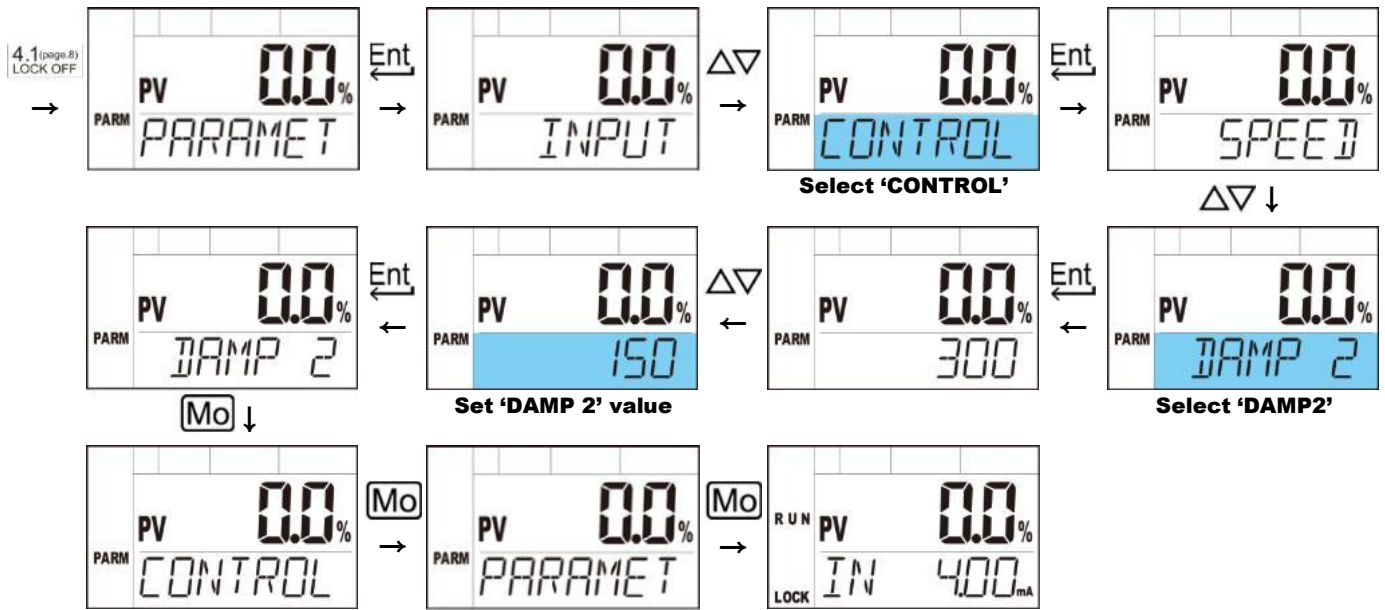

'DAMP 2' is automatically set during auto-calibration.

DAMP 1 (maximum control amount): maximum control amount

DAMP 2 (maximum section control amount): Maximum section control amount used in the range (INPUT SIGNAL  $\pm$  3%)

The 'DAMP 2' maximum section control amount is reflected only **at the INPUT SIGNAL  $\pm$  3%** position.

PID control amount > 'DAMP 2' control amount = 'DAMP 2' maximum section control amount

PID control amount < 'DAMP 2' control amount = PID control amount

If you increase the 'DAMP 2' setting value,

- ➔ The position value can be reached more quickly in the  $\pm$ 3% range.
- ➔ Hunting may occur due to sensitive control.

If you lower the 'DAMP 2' setting value

- ➔ The position value is slowly reached in the  $\pm$  3% range.
- ➔ If hunting occurs or if the value is lowered for a small valve, stable control is possible.



**It is recommended that DAMP 1 and DAMP 2 be adjusted together.**

### 4.8.4. [SENS] – Sensitivity Settings (Default Value: MIDDLE)

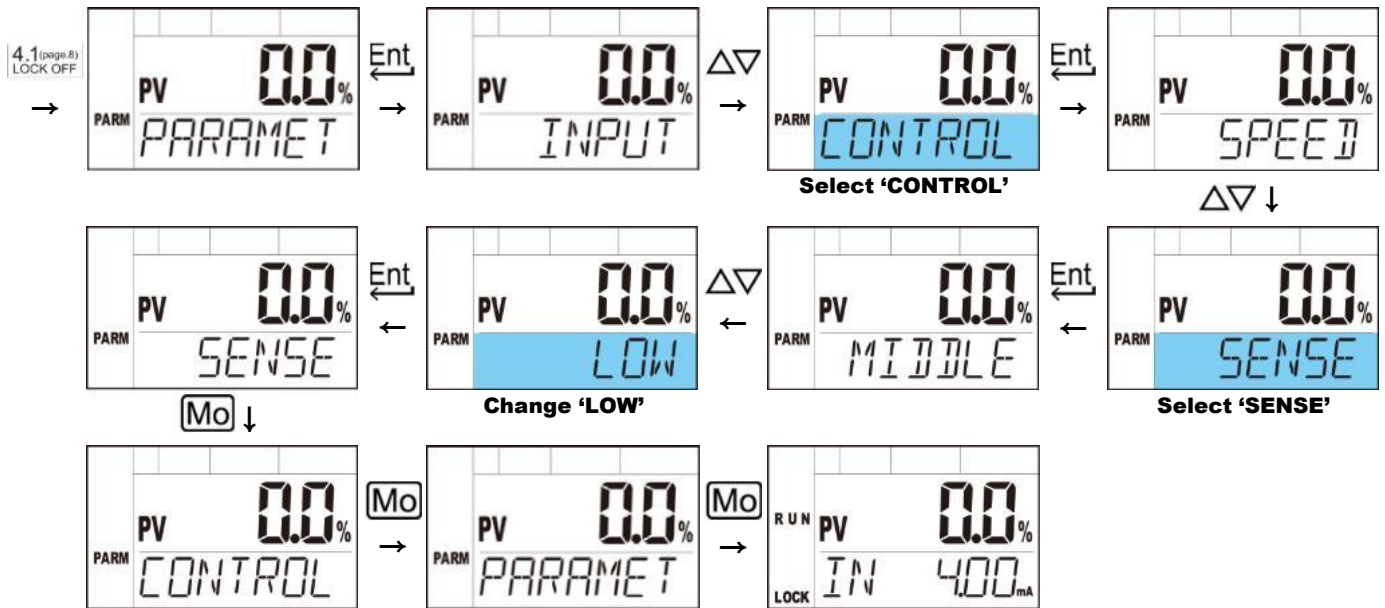

This parameter sets the sensitivity of the positioner.

You can easily change the positioner control performance by setting the sensitivity.

Division	Function	Note
MIDDLE	Positioner Default Value	-
LOW	Small volume valve Hunting occurs	Overshoot/undershoot may occur.
HIGH	Large volume valve A fast response speed	Hunting may occur.



If hunting occurs, please change it to LOW.

### 4.8.5. [LINEARI] Linearization compensation control

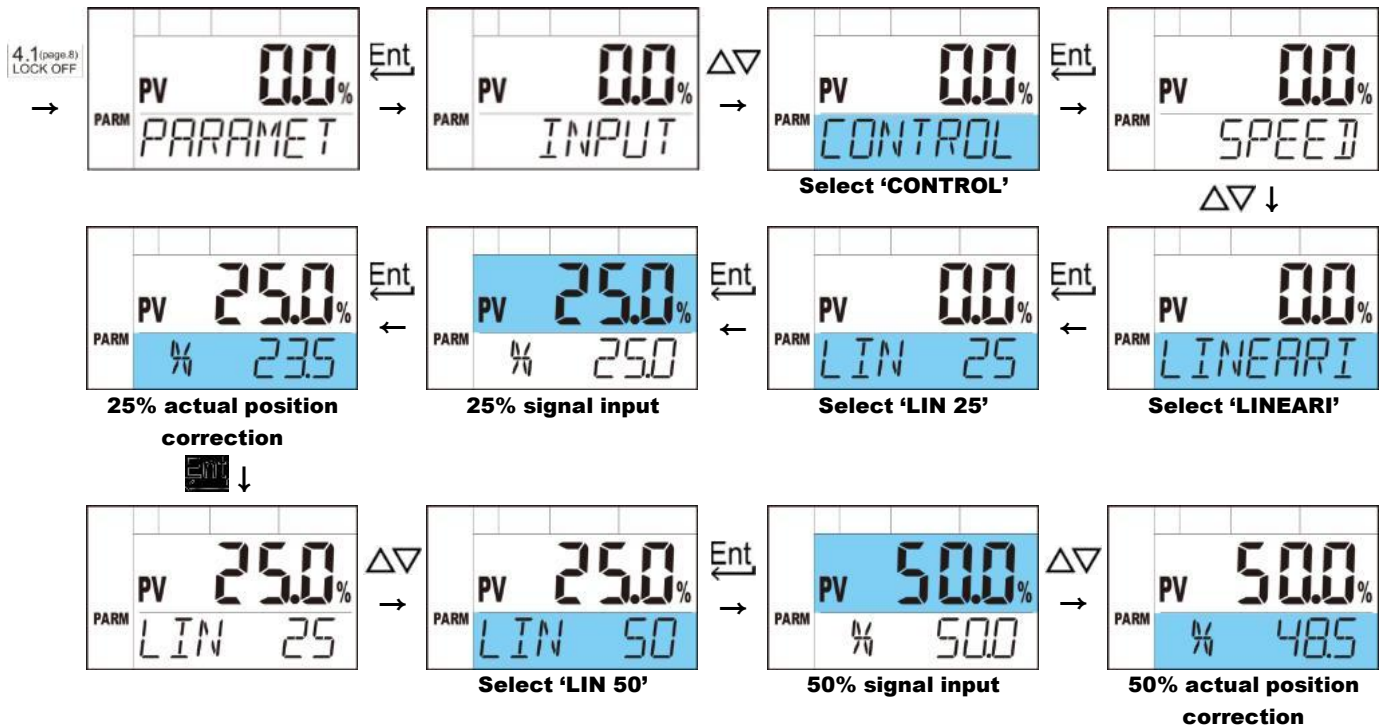

When controlling a device with linear motion, such as a globe valve, an error may occur in the intermediate value depending on the installation condition. (This does not occur with devices with rotary motion.)

The "LINEARIZATION" parameter is a function to compensate for this error.

The linearization compensation parameter is a function that compensates the position value in 25% increments to enable more precise control.

Linearization compensation requires an additional device to check the position, such as a dial gauge.

#### ※ How to set up LINEARIZATION

- 1) Input 25% of the input signal
- 2) Check the value of the dial gauge and device that can confirm the actual position
- 3) Correct the LIN25 value so that the actual position value is 25%.
- 4) Input 50% of the input signal
- 5) Correct the LIN50 value so that the actual position value is 50%
- 6) Input 75% of the input signal
- 7) Correct the LIN75 value so that the actual position value is 75%.
- 8) Compare the control value of 0 – 25 – 50 – 75 – 100% and the actual position value.
- 9) After re-calibrating the Insufficient position value and end the linearization setting.



- ① If the installation location of the positioner changes, the linearization settings must be reset.
- ② If the positioner is installed correctly, linearization work is not required.  
(When the valve is at 50%, the ideal positioner and lever are horizontal.)

### 4.8.6.[FRICTIO] FRICTION Compensation control (Default Value : NORMAL)

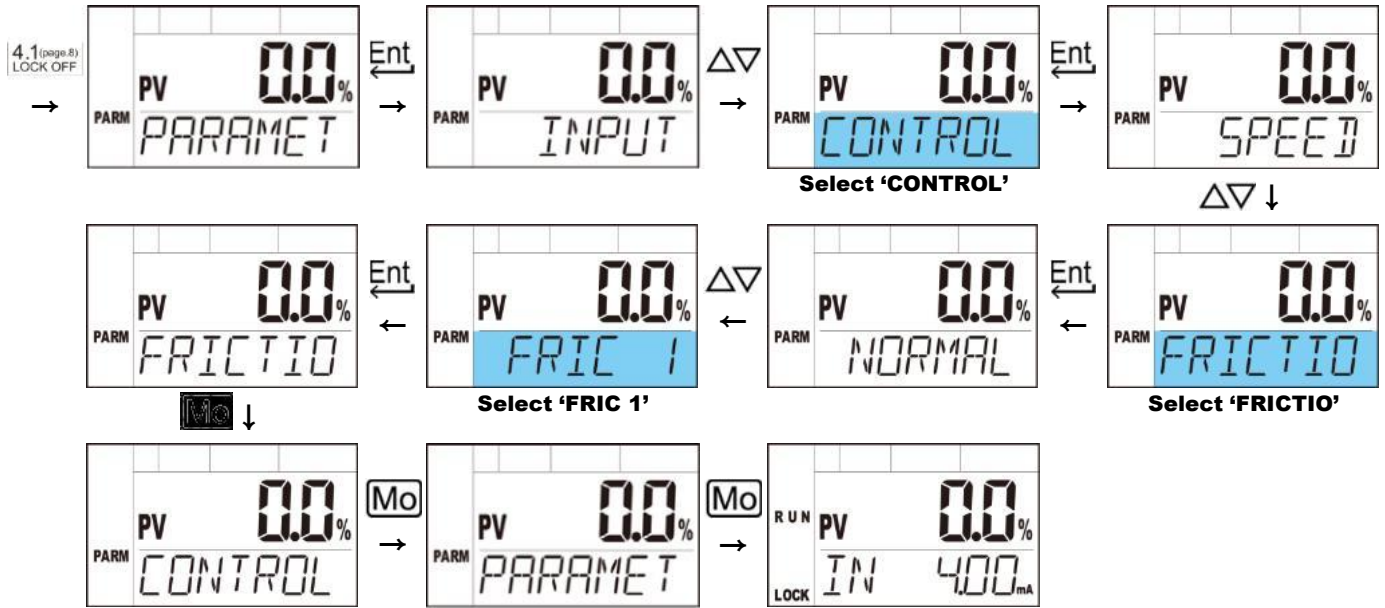

If continuous hunting occurs due to high friction, stable operation can be achieved using the FRICTION Parameter. Can be set in 3 levels depending on friction strength.

Division	Setting criteria	Tolerance
NORMAL	Default Value	I-GN setting value
FRIC 1	Hunting less than $\pm 1\%$	1% + I-GAIN setting value
FRIC 2	Hunting less than $\pm 2\%$	2% + I-GAIN setting value
FRIC 3	Hunting less than $\pm 4\%$	4% + I-GAIN setting value



- ① When FRIC 1 is set, the tolerance is set to 1%+ (PID's I-GAIN) value.
- ② If the I-GN value is 0.50, the tolerance is set to 1.5%.
- ③ I-GN will not be compensated if set to 0.00, so please set it to 0.01 or higher.

### 4.9.[DEADZON] Dead zone setting (Default Value: 0.3)

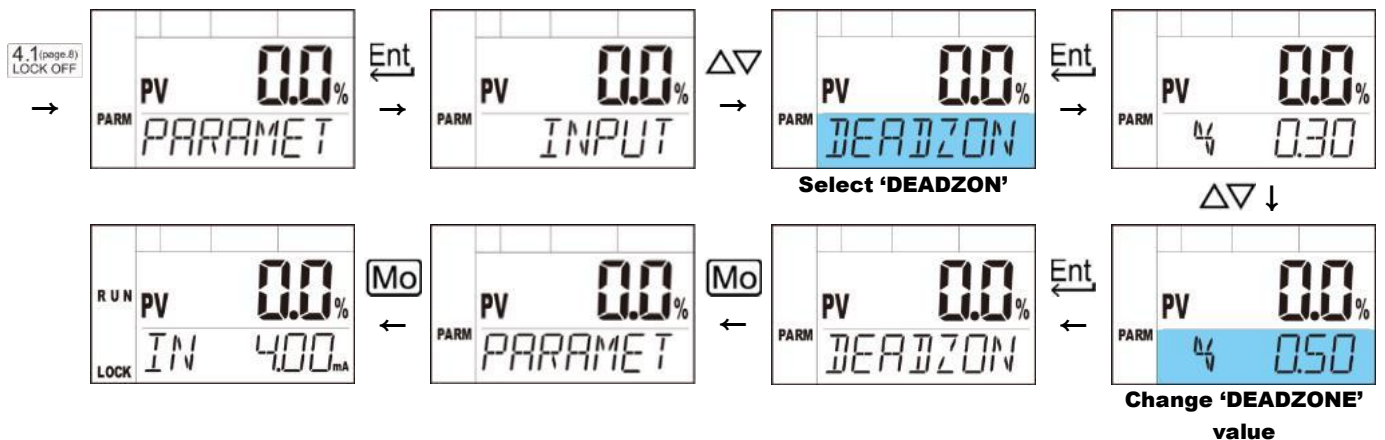

DEAD-BAND setting value is a parameter that sets the dead band area of the input INPUT SIGNAL value. The default setting is set to "0.3" and control is performed by directly reflecting the INPUT SIGNAL value. However, if external noise and fine adjustment are not required, the control can be made insensitive by raising the SIGNAL DEAD-BAND value.

## 5. SUB Parameter

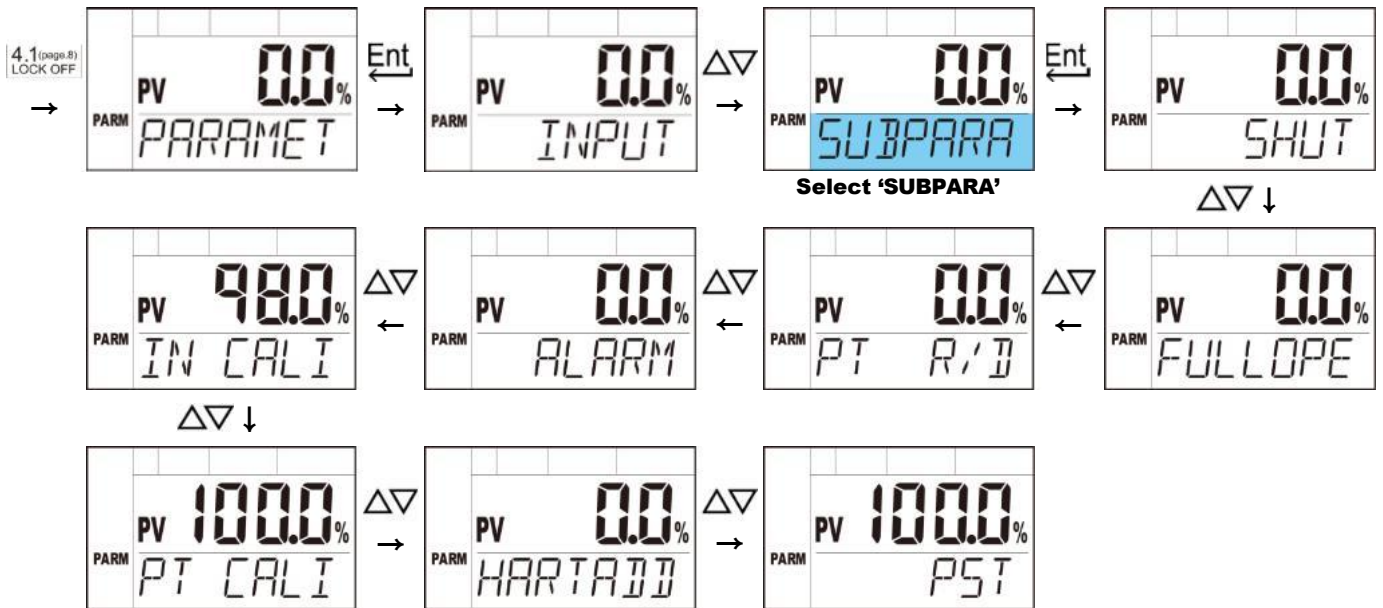

Ref.	Parameter	Description	Function	Default Value
5.1	SHUT	Shut-off	Forced closing section setting	0.5%
5.2	FULLOPE	Full-open	Forced opening section setting	99.7%
5.3	PT R/D	Output signal RA/DA	Direction setting of output signal	4...20mA
5.4	SPLIT	Split range	Split control settings	4...20mA
5.5	ALARM	Software limit low, high	Alarm limit settings	0...10%, 90...105%
5.6	IN CALI	Input signal calibration	4-20mA input signal correction	Factory setting
5.7	OUTCALI	Output signal calibration	4-20mA output signal calibration	Factory setting
5.8	HARTADD	HART polling address	0...255	0
5.9	PST	Partial stroke testing	Partial stroke test settings	OFF



1. Segment type display cannot be rotated.
2. Segment type display does not support multiple languages.
3. The positioner with self-adjustment function is changed to TFT LCD.

### 5.1.[SHUT] Valve shut-off control (Default Value: 0.5%)

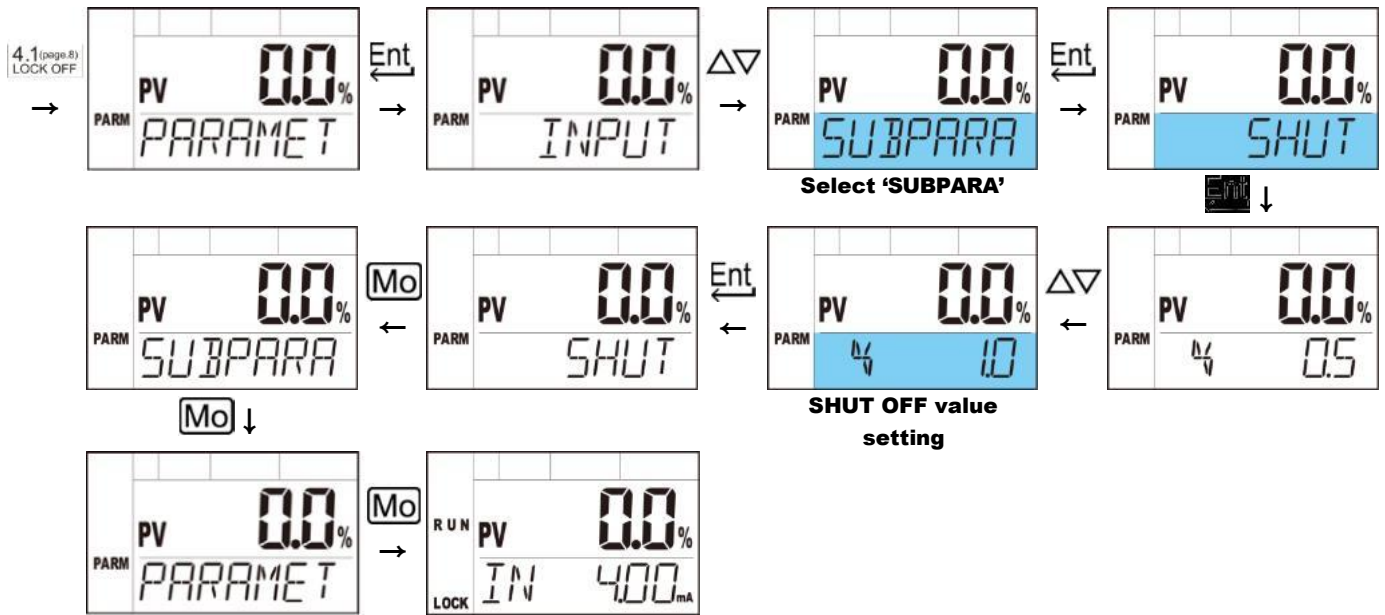

This is a safety feature that closes the valve completely.

This function forces the valve to close when the input signal is below the set value in order to prevent the valve from not being completely closed as intended due to inaccurate input signals or external noise.

For example, if a 0% signal is sent but the actual input signal is 0.8% due to some problem, the valve will not close completely and will open by 0.8%. In this case, the valve can be adjusted to be completely closed using the "SHUT" parameter.

It can be changed from 0 to 10.0%. The default value of 0.5% means the valve is fully closed between 4.000 and 4.080 mA. (0.1% = 0.016mA)

### 5.2.[FULL OPE] Valve full open control (Default Value : 99.7%)

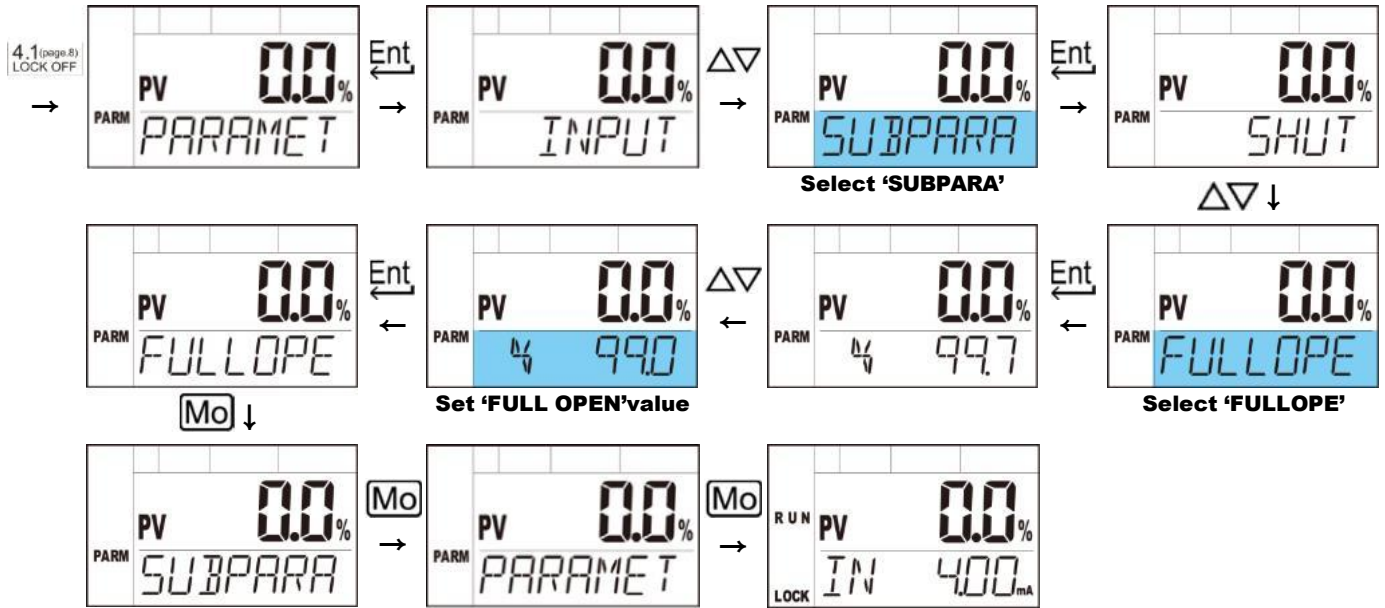

This is a safety feature that allows the valve to fully open.

To prevent the valve from not opening completely as intended due to inaccurate input signals or external noise, this function forces the valve to open when the input signal exceeds the set signal.

For example, if a 100% signal is sent, but the actual input signal is 99.0% due to some problem, the valve will not open completely and the valve will open 99.0%.

In this case, the valve can be adjusted to fully open using the "FULL OPEN" Parameter.

It can be changed from 50.0 to 100.0%. The default value of 99.7% means that the valve is fully open from 19.952 to 20.000 mA. (0.1% = 0.016mA)

### 5.3.[OUT] Feedback signal settings (Default Value: 4 - 20mA)

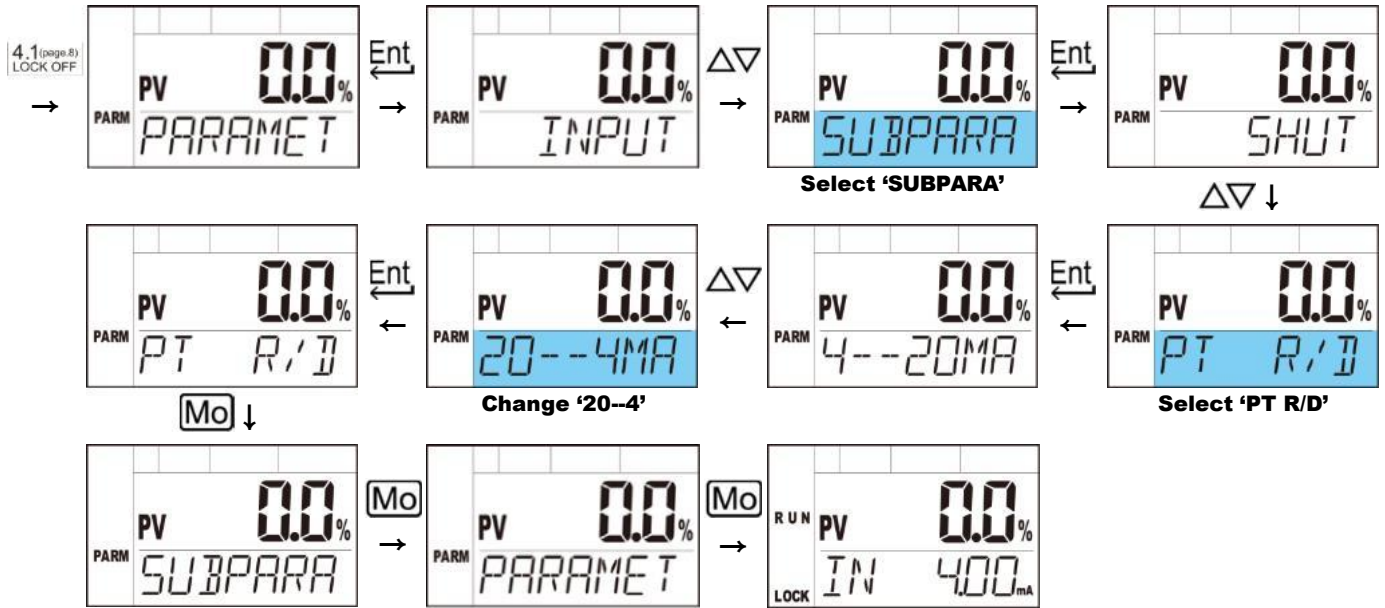

It is used in positioners with a built-in position transmitter

function, and is a parameter that changes the 4 – 20mA output to 20 – 4mA output.



If the position transmitter output value is incorrect, fine adjustment is possible in "4.7. PT CALI".

### 5.3.1. Position feedback wiring diagram

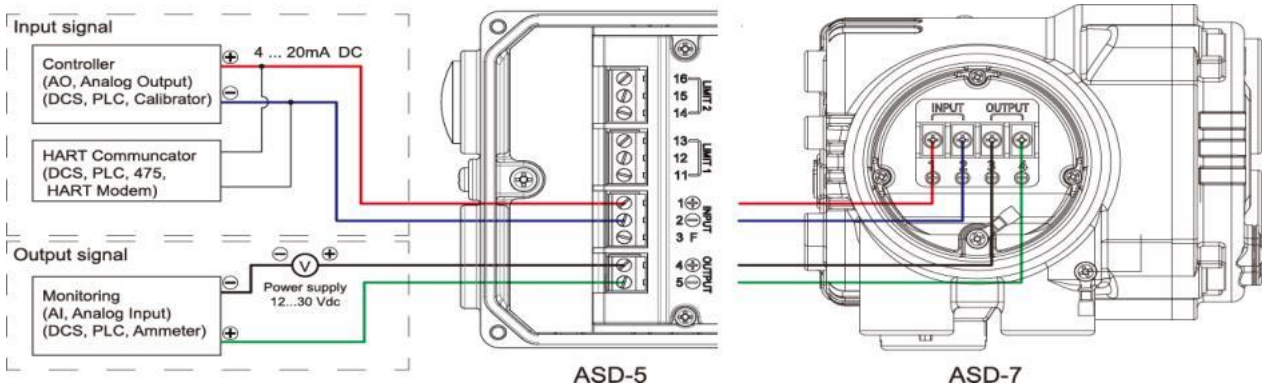

The position transmitter must be supplied with a separate external voltage of 12-30VDC.

### 5.4.[SPLIT] Split control settings (Default Value: 4-20)

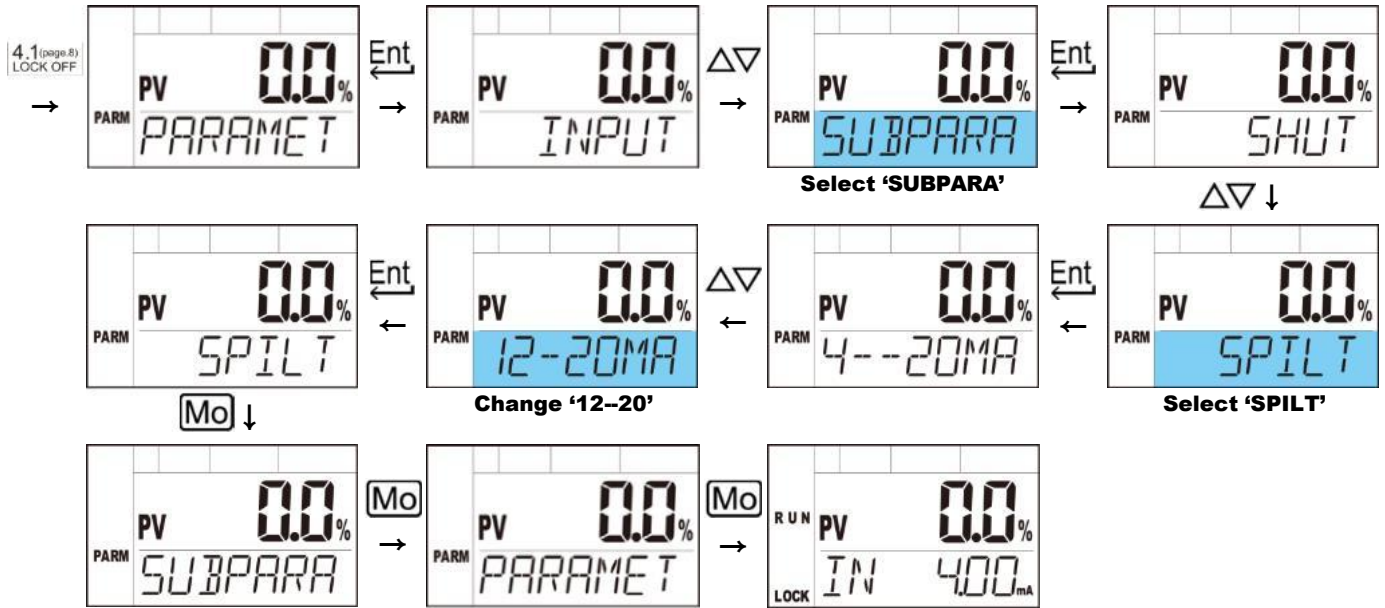

This is a function to set split control according to the input signal.

Three modes are supported: 4 to 20mA, 4 to 12mA, and 12 to 20mA.

The default is set to 4 to 20mA."

Used to continuously control two valves using one input signal.

Full stroke control signal for 1<sup>st</sup> stage valve: 4 ~ 12mA (0 ~ 100%)

Full stroke control signal for 2nd stage valve: 12 ~ 20mA (0 ~ 100%)

	4mA	8mA	12mA	16mA	20mA
Single stage valve	0%	50%	100%	100%	100%
Two stage valve	0%	0%	0%	50%	100%



When using split range, operation is possible only when using a controller with a capacity larger than the sum of the impedances of the two positioners.

If the allowable impedance is insufficient, output may not be output up to 20mA.

### 5.5.[ALARM] Set alarm limit (Default Value: 0 – 10%, 90 – 105%)

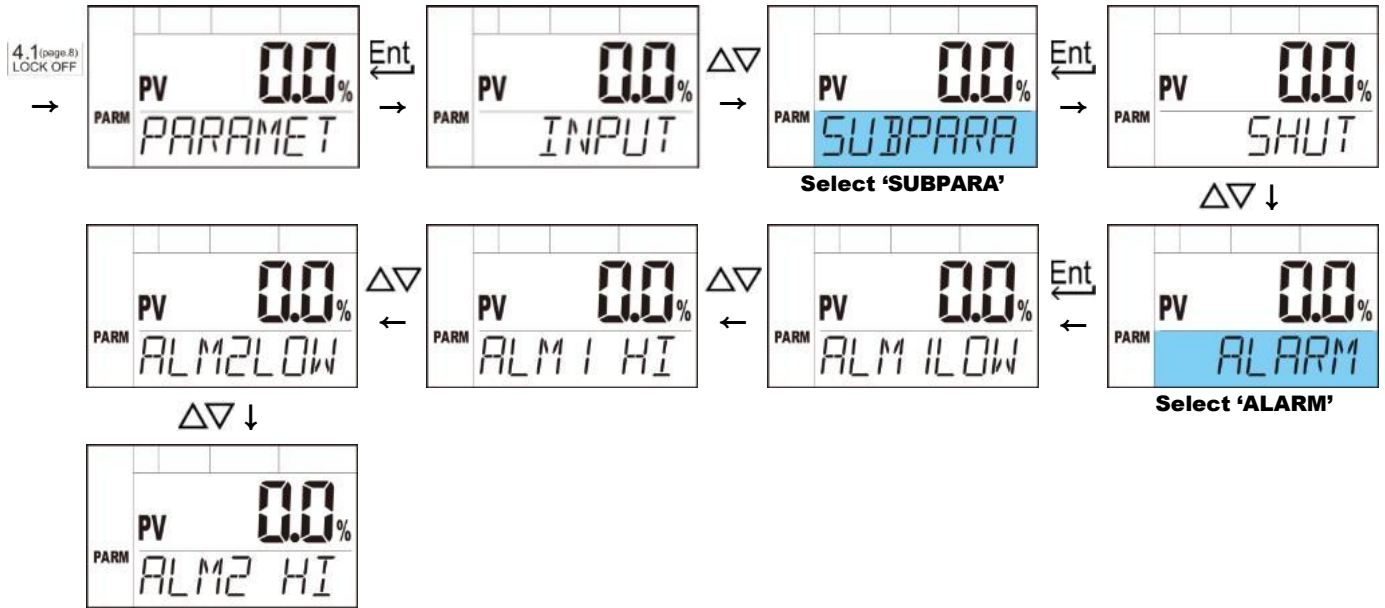

Division	Default Value	Note
ALM ILOW	0.0%	Terminal No. 11(+), 12(-)
ALM I HI	10.0%	
ALM2LOW	90.0%	Terminal No. 14(+), 15(-)
ALM2 HI	105.0%	

Used in positioners with built-in "Limit Switch – 2 x 24vdc Software Limit Switch" function.

You can set the open/close contacts of the control valve. When released from the factory, alarm limits are set to 0 – 10% for AL1 (L, H) and 90 – 105% for AL2 (L, H).

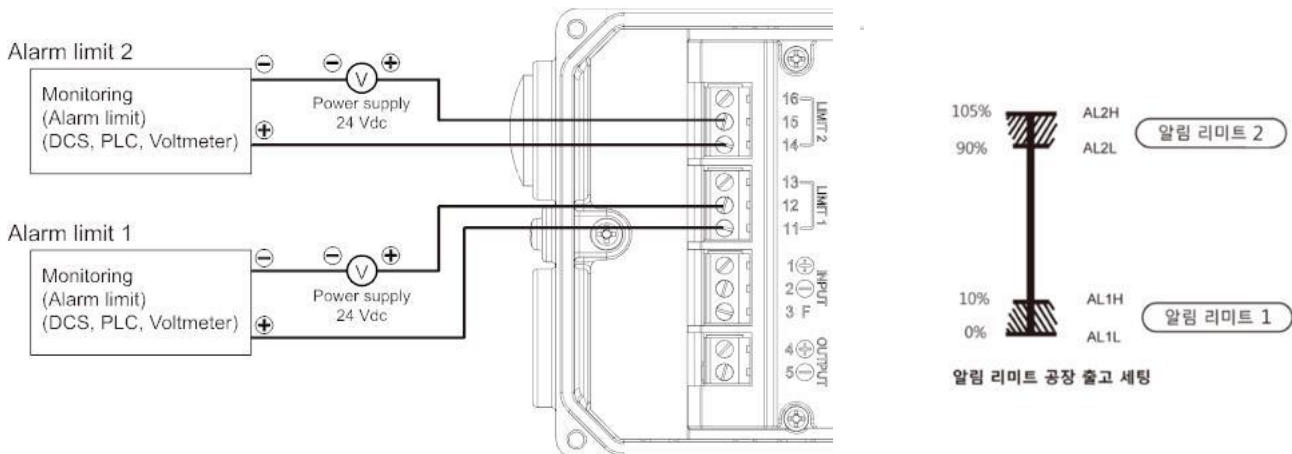

The software limit switch must be supplied with a separate external voltage of 24VDC. If the positioner's INPUT SIGNAL is not supplied, the alarm limit is not output.

### 5.6. [IN CALI] – INPUT signal correction (Default Value: factory setting)

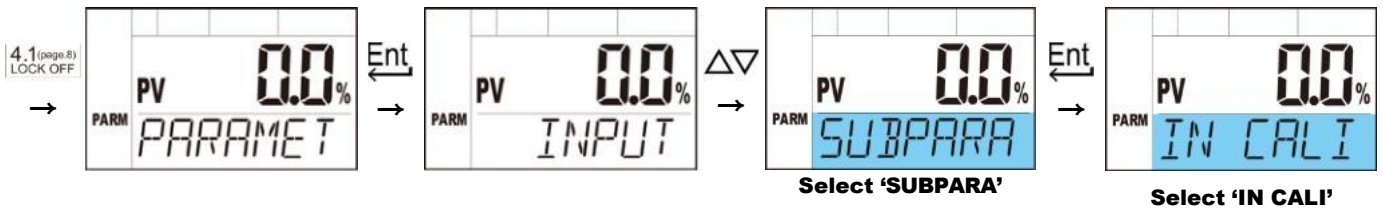

#### 5.6.1. INPUT 4mA default value setting

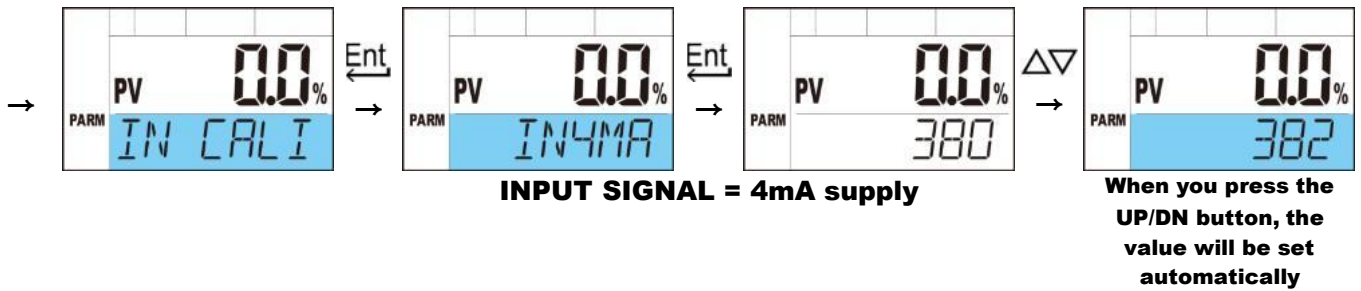

#### 5.6.2. INPUT 20mA default value setting

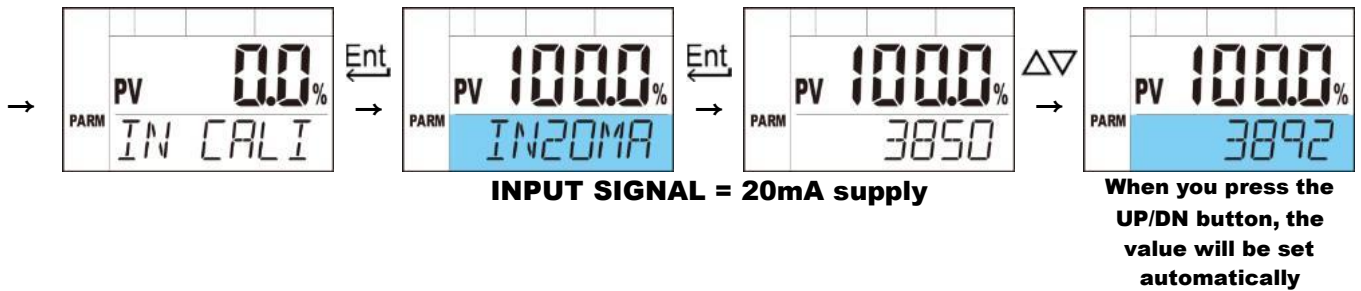

This parameter corrects 4.00mA and 20.00mA input signals.

If a 4.00mA signal is input, but the value confirmed by the positioner is higher or lower, it can be reset using INPUT calibration. 20.00mA can also be calibrated in the same way.



When setting IN CALIBRATION, please set it with the relevant current input.



If the settings are incorrect, major problems may occur in the positioner operation.

Reset or execute "4.5.4. "RESET".

## 5.7.[PT CALI] – Output signal correction (Default Value: factory setting)

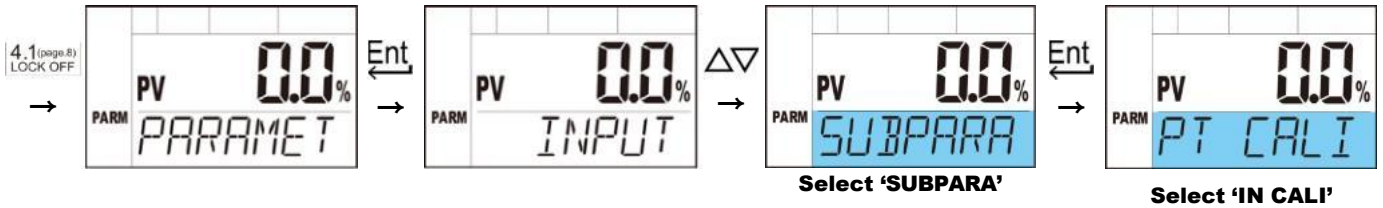

### 5.7.1. OUTPUT 4mA default value setting

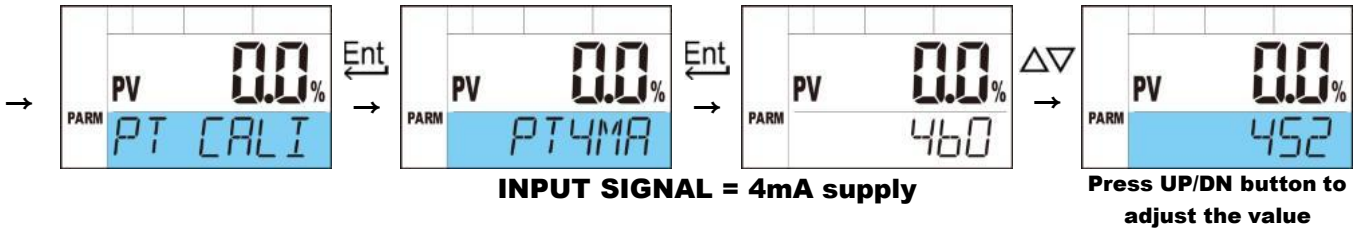

### 5.7.2. OUTPUT 20mA default value setting

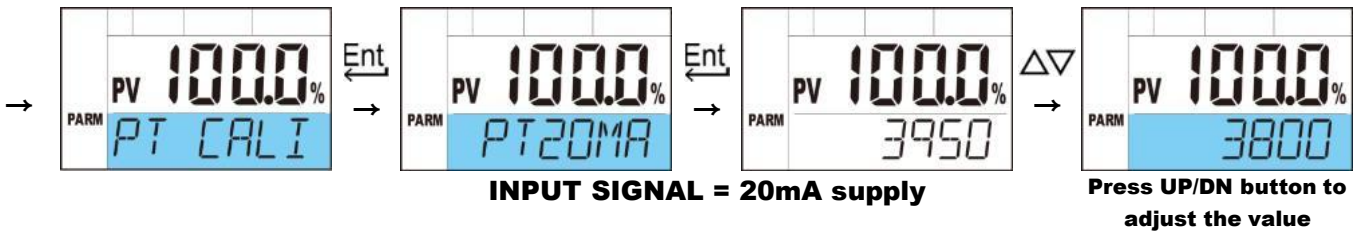

This parameter sets the 4/20mA value output from the positioner.

When released from the factory, it is set to output 4mA at 0% and 20mA at 100%.

If the output current value does not match, the output value can be adjusted by adjusting the OUT 4mA / OUT 20mA values.



The position transmitter must be supplied with a separate external voltage of 12-30VDC.

### 5.8. [HART ADD] – HART Communication address (Default Value: 0)

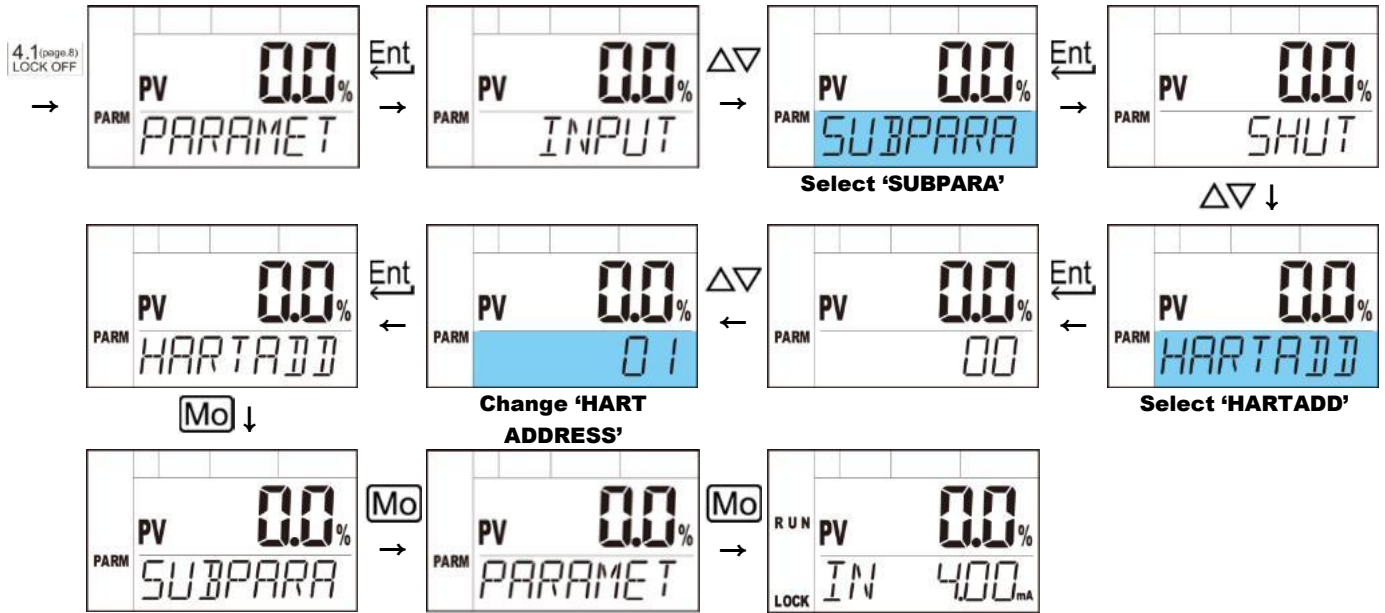

HART Communication polling address 0~63 is a parameter that can be modified locally. The default setting value is set to address "0".



Unexpected problems may occur if changes are made during HART communication, so be sure to change after disconnecting.



When the HART Address is changed, the positioner reboots.

Please check the safety of the surroundings before proceeding

### 5.9.[PST] – Partial Stroke Test (Default Value: OFF)

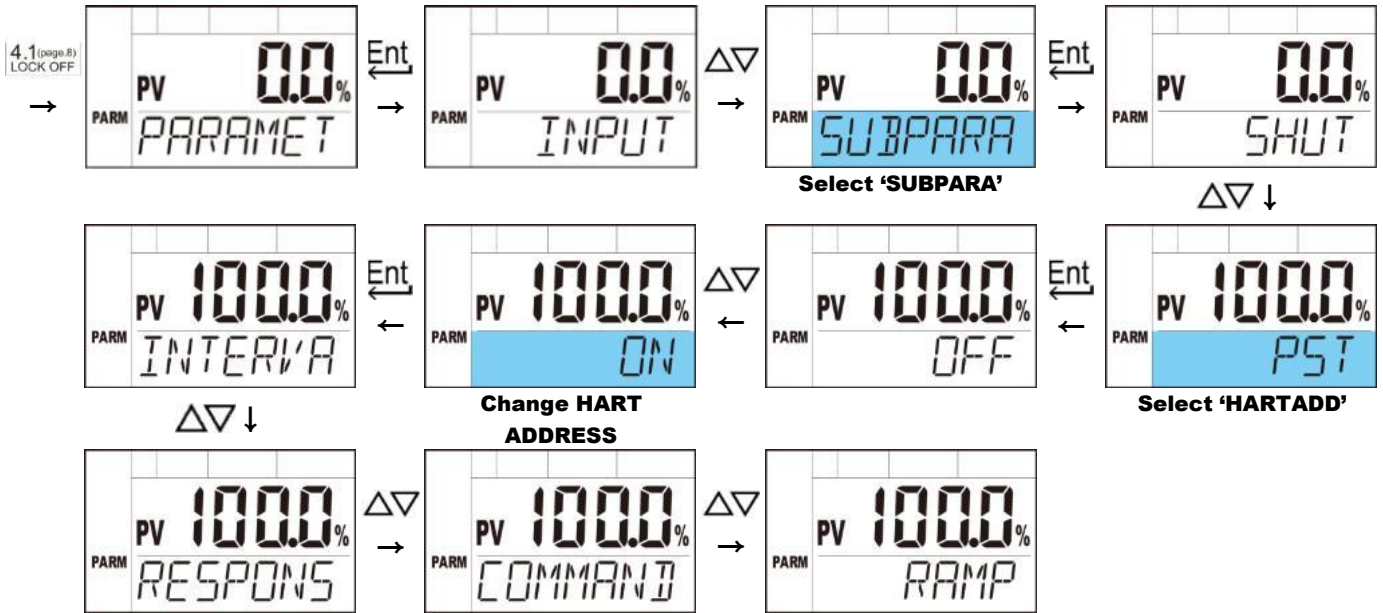

PST TEST moves at the "RAMP" rate as much as the "COMMAND" set at a certain "INTERVAL", and waits for the "RESPONSE" time when the "COMMAND" change amount is reached. If the position is within  $\pm 1.0\%$  within the "RESPONSE" time, "GOOD" is displayed. If it is outside, "BAD" is displayed.

Division	Explanation	Set range / Default Value
INTERVA	PST execution cycle settings	00 ~ 7999 hours Default Value : 24 hours
COMMAND	Size of change from current location	0.0 ~ 100.0% Default Value : 10.0%
RAMP	Setting change per second	1.0, 0.5, 0.25, 0.12, 0.06 %/sec Default Value : 1.0%/sec
RESPONS	After reaching "COMMAND" change amount Response waiting time	5, 10, 15, 20, 30sec Default Value : 10sec

#### 5.9.1.[INTERVA] : Set PST execution cycle

- When set to "00HR", PST runs every minute. You can use it for initial setup and testing.

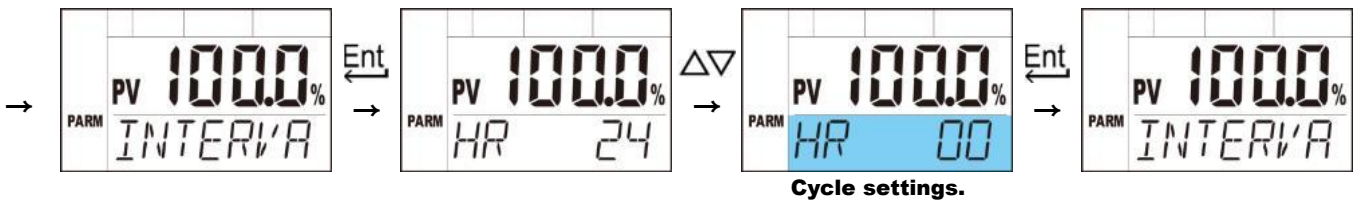

### 5.9.3. [COMMAND] : Set the change size (Default Value: 10%)

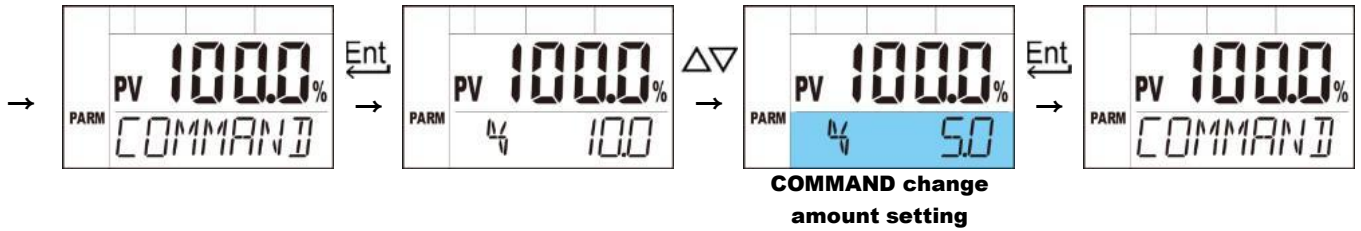

It moves from the current position as much as the "COMMAND" setting value.

When set to "COMMAND 5%, the valve moves from 100.0% -> 95.0% -> 100.0%.



- Valve position > 50% : value increases in the direction of increase

- Valve position < 50% : value decreases in decreasing direction

### 5.9.4.[RAMP] : Change amount per second (Default Value : 1.0%)

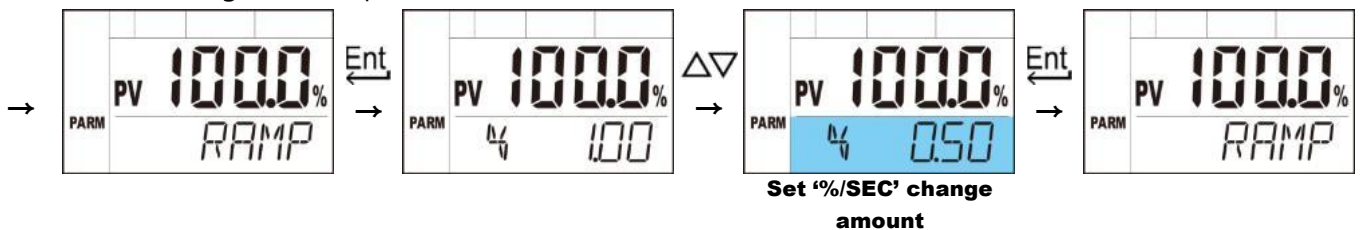

- The amount of change per second can be selected from 1.0, 0.5, 0.25, 0.12, or 0.06%/sec.

### 5.9.5. [RESPONS] : Response waiting time (Default Value: '10' seconds)

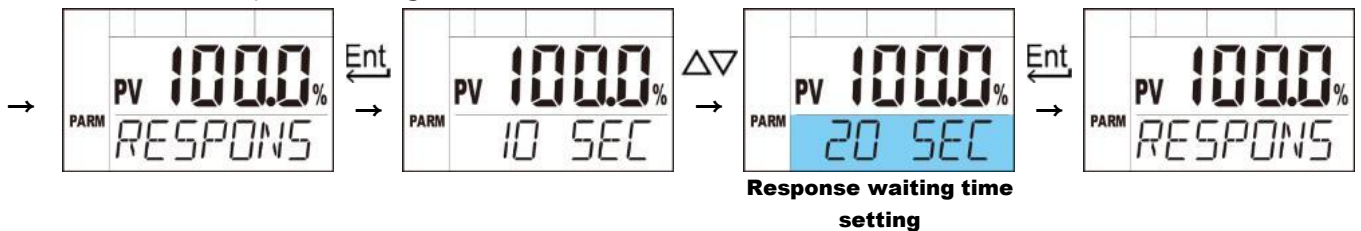

After setting the above parameters, run PST. Even if the first results are marked as 'Good', If set too long, it does not provide a good reference point for future comparisons.

Also, if 'Bad' is displayed, RESPONS is set too small and the time must be increased.

		If the dead zone of the SET position is reached within the time set in RESP, it indicates that there is no problem.
		If the dead zone at the SET position is not reached within the time set in RESP, it can be an indicator to determine whether there is a problem with the movement of the valve.

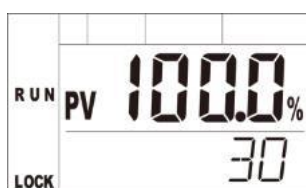

PST – RESPONSE : When set to 00HR, the count ranges from 0 to 60 as shown in the picture displayed and PST is executed repeatedly. Please reset "INTERVA" after completing the TEST.

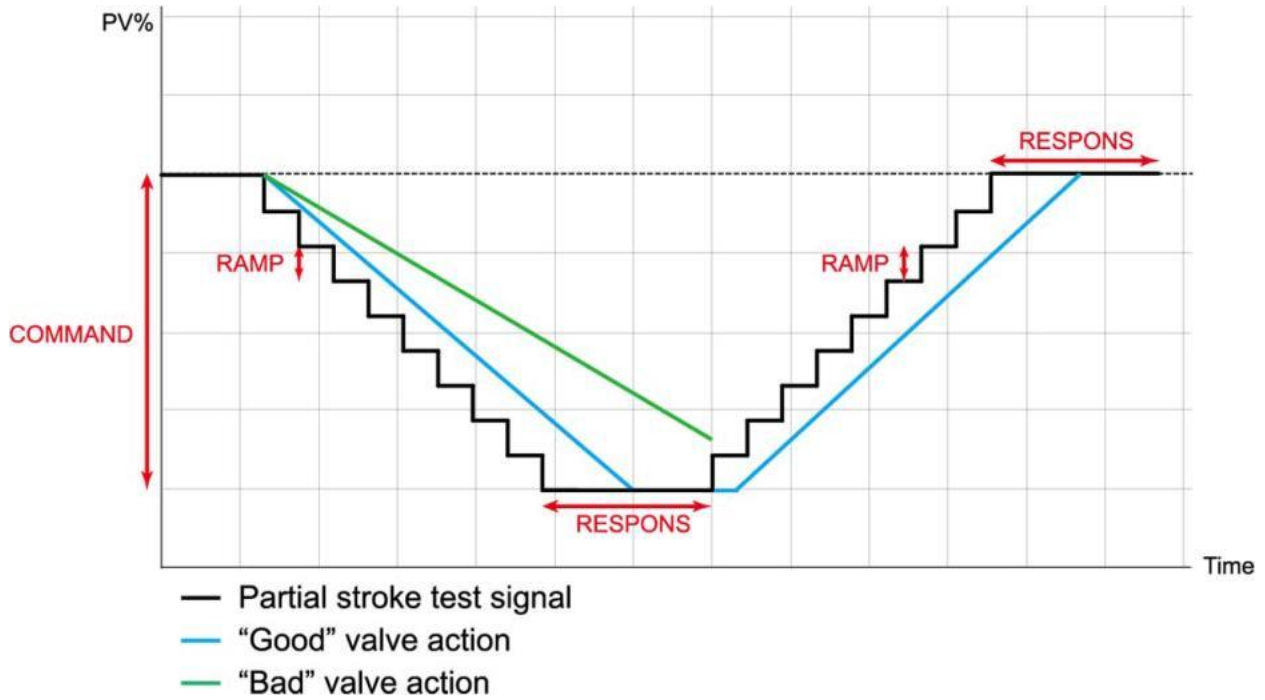

-PST can be used to prevent valve-packing sticking even if the valve is stopped in a certain position for a long period of time.

-If you do not use PST, be sure to set it to OFF.

-When auto-calibration is performed, it is automatically set to OFF.

## Warranty

1. The warranty period of the product is 1 years after the product is shipped from Power-

Genex in Korea.

2. For any failure or damage reported within the warranty period which is clearly our responsibility, a replacement product or necessary parts will be provided. This limited warranty applies only to our product independently, and not to any other damage incurred

due to the failure of the product.

3. If a problem happens with the following reasons, please note that the reasonable repairing

costs will be charged even during a warranty period.

- In case that customers retro-fit the products improperly without any instructions from

- ~~In case that the products are damaged by a bad delivery, storage or handling beyond~~

- ~~In case that the products are used beyond specifications~~

- In case that the products are damaged by an improper installation

- In case that the products are damaged by fire, earthquake, storm, flood, thunder,

lighting, other natural disasters, riot, war, exposure to radioactivity

4. If maintenance is required, please contact distributors or Power-Genex directly. A proper

and satisfactory customer service will be provided.



# PVF POSITIONER

Address: Address to be updated Here

Tel: 071 354 8587

Email: [info@pvfpositioner.co.za](mailto:info@pvfpositioner.co.za)

Web: [www.pvfpositioner.co.za](http://www.pvfpositioner.co.za)



Subject to change without prior notice